

*Designed to inspire.*  
BUILT TO LAST.



Cladding • Windows • Doors • Soffit & Fascia • Rainware • Building Envelope • Tools & Equipment

*For more than 50 years,*

Gentek Building Products has been the premier choice for beautiful products, impeccably built. Our wide array of materials, profiles, colours and finishes expertly achieve high-performance design with easy-care simplicity – exactly what today’s homeowners are looking for. When it comes to choosing the best materials for your next project, you can depend on Gentek for quality and style like no other.

- 4** Colour & Design Inspiration
- 6** Sequoia® Select EnFusion®
- 8** Sequoia® Select
- 10** Northern Forest® Elite
- 12** Board & Batten
- 13** Fair Oaks®
- 14** Concord®
- 15** Driftwood® II
- 16** Advantage® III/Berkshire™ Beaded
- 17** Shakes & Shingles
- 18** Deluxe™ Aluminum
- 19** Woodgrain™ 2000
- 20** Distinction
- 21** Longboard®
- 22** ChamClad
- 23** Versetta Stone®
- 24** Everlast®
- 25** James Hardie®
- 26** Sierra™ Steel
- 28** Soffit & Fascia
- 30** Rainware & Gutter Guards
- 31** Columns, Shutters & Blocks/Vents
- 32** Regency® 400 Series Windows
- 33** Regency® Windows
- 34** 80 Series Windows
- 35** 70 Series/Amherst™ Windows
- 36** Doors
- 38** Building Envelope
- 39** Tools & Equipment
- 40** Colour Matrices
- 46** Architectural Specifications

For trim, accessories, gutter coil and other product information, please see the detailed Gentek Product Directory.





Gentek siding, windows, doors and trim accessories bring easy living to the forefront. The premium appearance provides the beauty of freshly painted or stained wood but without the worries of rotting, splitting, warping or insect damage. This extensive product collection offers every “must have” for upscale style in a virtually maintenance-free home exterior.

### **THE BEAUTY OF SUPERB CRAFTSMANSHIP**

Featuring best-in-class materials and cutting-edge technology, Gentek products are performance-engineered to beautifully withstand harsh weather elements, including pounding rain, high winds, intense heat and frigid cold. And thanks to fade-defying colour formulations, our darker sidings provide superior colour retention and resistance to weathering – ensuring the luxurious finish stays true.

### **FUTURE-FORWARD AND VALUE-RICH**

For most people, a home is a source of pleasure and pride, as well as an important investment. Gentek products not only will create an attractive finish, they will heighten the home’s curb appeal as well. And in today’s resale market, a beautiful, low-maintenance exterior can be a valuable amenity.

### **GENTEK SETS THE STAGE FOR SUCCESS!**

Choosing just the right products, profiles and colours makes it possible to reveal each home’s perfect potential. Horizontal, vertical and specialty siding are just the starting point. Beautiful new windows, doors, rainware, decorative trim accents and more complete the picture. Gentek also offers a full selection of building envelope products, tools and equipment to streamline your projects with simplicity and ease.

# Design inspiration starts here.

The power of colour is undeniable when creating a beautiful home exterior. From sublime palettes in monochromatic tones to bold contrasting architectural hues, colour defines the design. Gentek products are available in a grand scale of colourful options that let you tailor the look with signature style.



## SIDING WITH PERFECTION

Perfection? It's never too much to ask. Our Colour Clear Through system makes it easy to find the perfect colour match for your exterior designs. This exclusive selection of customer-preferred colours ensures that all Gentek products – siding, soffit, fascia, trim and rainware – will beautifully match throughout our vinyl, aluminum and steel product lines.



There's no need to settle for siding and trim that *almost* match. With our special Colour Clear Through palette, you can depend on a consistent match through and through.

## CHOOSE DARKER COLOURS WITH CONFIDENCE

Richer, more resilient colours. A luxurious, low-luster finish with a depth of visual appeal. Enduring beauty and performance. Gentek vinyl siding has never been better – thanks to ChromaTrue® fade-defying colour technology.

This advanced copolymer compound fortifies our darker colour sidings with superior colour retention and protection from the elements, including exposure to intense sun and heat, pounding rain, saltwater and chemicals. ChromaTrue also provides a highly weatherable finish that stands up strong to dings and abrasions.



## CUSTOM-PAINTED WINDOWS

Regency 400 Series and Regency window exteriors can be custom painted to match any of our trim colours, allowing you to achieve a truly upscale appearance for your exterior design. Regency 400 Series interior colour is extruded Nordic White, while Regency interior colour choices are extruded White and Beige, or an optional Dark Oak Woodgrain laminate.



### Matching Accents

Door trim, porch railing and other exterior accents can be painted to match your Gentek siding and windows. Gentek proudly offers Dulux exterior paint for all of Gentek's most popular colours. Please note that paint colour codes are formulated for Dulux paint only.



**ChromaTrue**

Featuring richer, darker colours fortified with ChromaTrue technology, Gentek-brand vinyl siding carries a lifetime limited warranty against fading.



## GENTEK VISUALIZER

Take your renovation projects to the next level with the Gentek Visualizer. This easy-to-use program lets you create “before and after” shots featuring a variety of colour schemes that showcase your renovation ideas.

- Design-ready with a gallery of house images; access it from any mobile device and start designing.
- Custom “photo-realistic” option – upload a photo of your customer’s home or simply enter the address and Google Street View will upload the photo for you. Use the design tools to apply products to your photo (our design team also can professionally prep the photo for you).
- Pre-selected Gentek product and colour combinations for easy design selection.
- Save your preferred products, colours and designs – everything is listed and ready to go.

Visit [gentek.ca](http://gentek.ca) and click on the Gentek Visualizer to explore design options for your next project.



## FREE DESIGN ADVICE – JUST FOLLOW THE BLOG

Whether you want to simply refresh the appearance of a home – or press the reset button – Gentek is here to help! Just follow our MyDesign Home Studio blog at [mydesignhomestudio.com](http://mydesignhomestudio.com) to enjoy a wide range of design tips and renovation ideas, as well as a question and answer portal offering professional design advice for any project.

And ask your Gentek Sales Representative about our Gentek RenoPro Software that can be personalized for your business.



**Product Specifications:**

**Nominal Thickness:** Vinyl panel .046"  
**Windload:** Laboratory tested to withstand windloads up to Category 5 Hurricane rating  
**Texture:** Cedargrain

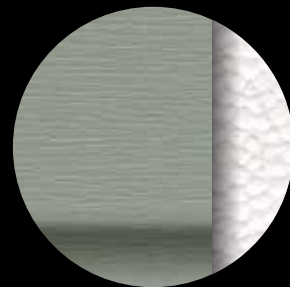

House shown in Canyon Clay.

**Classic Colours**

Snow White	Canyon Clay	Dover Gray
Almond	Pebble	Storm
Wicker	Sage	Chesapeake Gray

**Designer Colours**

Dark Drift	Rockwell Blue	Hudson Slate
Meadow Fern	Midnight Surf	Windswept Smoke
Moonlit Moss		

**THE NEW STANDARD IN QUALITY AND ENERGY SAVINGS**

**Energy-Smart Design** Custom-contoured expanded polystyrene rigid foam insulation (up to 1-1/4" thick\*) helps block energy loss year-round.

**Greater Impact Resistance** Up to 400% more impact resistance than conventional "hollow back" siding.

**Superior Perm Rating of 5** Allows insulation to breathe and moisture to escape, not get trapped inside.

**Full-Roll Nail Hem** Heavy-duty, double-thick wall attachment increases strength and structural integrity.

**Built Hurricane-Tough!** Laboratory tested to withstand winds up to Category 5 Hurricane rating.

**Beautiful Wood-Like Appearance** Natural cedargrain texture and low-gloss finish for subtle elegance.

**Longer Panels** The extra-long 16'8" and 16'4" panel lengths create fewer overlaps for a superior finished look.

\*Nominal.

## INTELLIGENT SIDING SOLUTIONS

A fusion of beauty and strength, Sequoia Select EnFusion helps prevent energy loss to keep your home warm and cozy in the winter and refreshingly cool in the summer – with less energy spending. The laminated, rigid foam insulation is contoured to fill the gap between the siding and your home to provide superior energy efficiency. This protective layer also conceals imperfections in the underlayment to ensure smooth wall lines and an upscale appearance.

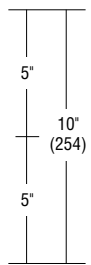

### Double 5" Dutch Lap

Insulated Panel with 1-1/4"  
Overall Panel Thickness (31.75)  
3/4" Butt (19)  
2-5" Exposure per Panel  
(127/254)  
16'4" Lengths (4979)

**Packaging:**  
7 pcs. per ctn.  
.95 sq. per ctn. (8.84 m<sup>2</sup>)  
Ship. wt: 56.8 lb (25.8 kg)

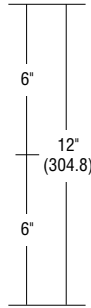

### Double 6" Clapboard

Insulated Panel with 1-1/4"  
Overall Panel Thickness (31.75)  
3/4" Butt (19)  
2-6" Exposure per Panel  
(152.4/304.8)  
16'8" Lengths (5080)

**Packaging:**  
6 pcs. per ctn.  
1 sq. per ctn. (9.3 m<sup>2</sup>)  
Ship. wt: 55.7 lb (25.3 kg)



**Warranty Coverage:**  
Lifetime Limited Warranty  
Lifetime Limited Fade Coverage  
Lifetime Limited Hail Coverage

Please see detailed product directory for accessory information.  
For metric, unless indicated otherwise, all measurements are in millimeters (mm).



# SEQUOIA SELECT

Ultra-Premium Vinyl Siding

**Product Specifications:**

**Nominal Thickness:** .046"  
**Windload:** Laboratory tested to withstand windloads up to 407 km/h (253 mph)\*  
**Texture:** Cedargrain



**Classic Colours**

Snow White	Wicker	Dover Gray
Sandstone	Canyon Clay	Storm
Linen	Pebble	Chesapeake Gray
Almond	Monterey Sand	Sage
Maize	Pearl	Juniper Grove

**Designer Colours**

Majestic Brick	Meadow Fern	Marine Dusk
Dark Drift	Moonlit Moss	Hudson Slate
Rockport Brown	Rockwell Blue	Windswept Smoke
Espresso	Coastal Blue	Iron Ore
Smoked Timber	Midnight Surf	

**THE ULTRA-PREMIUM DISTINCTION**

**Extra-Heavy Wall Thickness** Heavy-duty .046" thickness provides superior rigidity, ensuring straight, smooth walls.

**Full-Roll Nailing Hem** Delivers double-strength wall attachment.



**Exclusive Advantage Lock System** Securely connects panels, greatly enhancing rigidity and stability.

**Hurricane-Velocity Wind Resistance** Built hurricane-tough! In laboratory tests simulating hurricane-force wind conditions, Sequoia Select withstood windloads up to 407 km/h (253 mph).\*

**Rich Cedargrain Emboss** Beautiful low-gloss finish achieves natural appeal and excellent durability; requires minimal upkeep.

**Superior Lap Height** Full 3/4" lap height creates a deeper dimension and enhanced shadow lines for a true wood look.

\*Windload performance may vary by profile design.

Double 5" Clapboard and Double 5" Dutch Lap not available in Designer Colours in British Columbia and Alberta.



## A PREMIER HOME EXTERIOR

Exquisite style, exceptional strength – that’s the hallmark of Sequoia Select ultra-premium vinyl siding. Greater panel thickness and deeper dimension. An extraordinary hurricane-velocity wind resistance up to 407 km/h (253 mph).\* A luxurious low-gloss finish embossed with a rich cedargrain texture. All in a generous selection of 29 beautiful colours and 4 classic profiles for tastefully stated elegance.

House shown in Iron Ore.

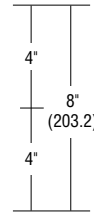

### Double 4" Clapboard

3/4" Butt (19)  
2-4" Exposure per Panel  
(101.6/203.2)  
12'6" Lengths (3810)

**Packaging:**  
24 pcs. per ctn.  
2 sqs. per ctn. (18.6 m<sup>2</sup>)  
Ship. wt: 112 lb (50.8 kg)

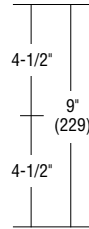

### Double 4-1/2" Dutch Lap

3/4" Butt (19)  
2-4-1/2" Exposure per Panel  
(114.5/229)  
12'1" Lengths (3683)

**Packaging:**  
22 pcs. per ctn.  
2 sqs. per ctn. (18.6 m<sup>2</sup>)  
Ship. wt: 102.5 lb (46.5 kg)

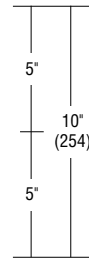

### Double 5" Clapboard

3/4" Butt (19)  
2-5" Exposure per Panel  
(127/254)  
12' Lengths (3658)

**Packaging:**  
20 pcs. per ctn.  
2 sqs. per ctn. (18.6 m<sup>2</sup>)  
Ship. wt: 100 lb (45 kg)

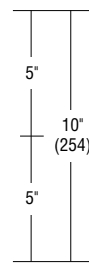

### Double 5" Dutch Lap

3/4" Butt (19)  
2-5" Exposure per Panel  
(127/254)  
12' Lengths (3658)

**Packaging:**  
20 pcs. per ctn.  
2 sqs. per ctn. (18.6 m<sup>2</sup>)  
Ship. wt: 102.5 lb (46.5 kg)



#### Warranty Coverage:

Lifetime Limited Warranty  
Lifetime Limited Fade Coverage  
Lifetime Limited Hail Coverage

Please see detailed product directory for accessory information.  
For metric, unless indicated otherwise, all measurements are in millimeters (mm).



# NORTHERN FOREST® ELITE

Ultra-Premium Vinyl Siding

## Product Specifications:

**Nominal Thickness:** .046"

**Windload:** Laboratory tested to withstand windloads up to 407 km/h (253 mph)\*

**Texture:** Cedargrain



### Variegated Colours

Aspen

Willow

Earthen

Rainforest



### LUXURY MEETS PERFORMANCE

**Extra-Heavy Wall Thickness** Heavy-duty .046" thickness provides superior rigidity, ensuring straight, smooth walls.

**Full-Roll Nailing Hem** Delivers double-strength wall attachment.



**Exclusive Advantage Lock System** Securely connects panels, greatly enhancing rigidity and stability.

**Built Hurricane-Tough!** In laboratory tests simulating hurricane-force wind conditions, Northern Forest Elite withstood windloads up to 407 km/h (253 mph).\*

**Integrated Variegated Colour** Warm, earthy hues in various densities create the distinctive beauty of hand-brushed stained cedar.

**Rich Cedargrain Emboss** Beautiful low-gloss finish achieves natural appeal and excellent durability; requires minimal upkeep.

**Superior Lap Height** Full 3/4" lap height creates a deeper dimension and enhanced shadow lines for a true wood look.

\*Windload performance may vary by profile design.

## CASUAL BUT NEVER ORDINARY

Inspired by the beauty of our own world-renowned woodlands, Northern Forest Elite ultra-premium vinyl siding will give your home the distinctive allure of a natural wood finish but without the time-consuming upkeep.



House shown in Aspen.

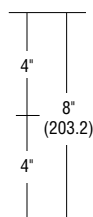
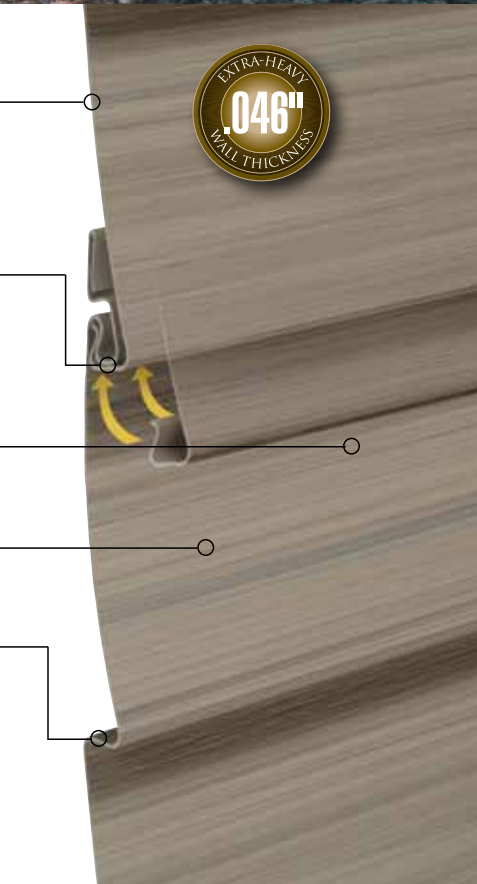

### Double 4" Clapboard

3/4" Butt (19)  
2-4" Exposure per Panel (101.6/203.2)  
12'6" Lengths (3810)

**Packaging:**  
24 pcs. per ctn.  
2 sqs. per ctn. (18.6 m<sup>2</sup>)  
Ship. wt: 112 lb (50.8 kg)

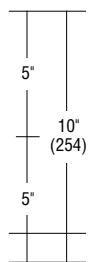

### Double 5" Clapboard

3/4" Butt (19)  
2-5" Exposure per Panel (127/254)  
12' Lengths (3658)

**Packaging:**  
20 pcs. per ctn.  
2 sqs. per ctn. (18.6 m<sup>2</sup>)  
Ship. wt: 100 lb (45 kg)

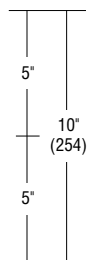

### Double 5" Dutch Lap

3/4" Butt (19)  
2-5" Exposure per Panel (127/254)  
12' Lengths (3658)

**Packaging:**  
20 pcs. per ctn.  
2 sqs. per ctn. (18.6 m<sup>2</sup>)  
Ship. wt: 102.5 lb (46.5 kg)

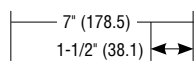

### 7" Vertical Board & Batten

1/2" Batten Height (12.7)  
1-1/2" Batten Width (38.1)  
7" Exposure per Panel (178.5)  
10' Lengths (3048)

**Packaging:**  
17 pcs. per ctn.  
1 sq. per ctn. (9.2 m<sup>2</sup>)  
Ship. wt: 50 lb (23 kg)

Note: 7" Vertical Board & Batten has a nominal thickness of .048" and a light roughsawn texture.



**Warranty Coverage:**  
Lifetime Limited Warranty  
Lifetime Limited Fade Coverage  
Lifetime Limited Hail Coverage

Please see detailed product directory for accessory information.  
For metric, unless indicated otherwise, all measurements are in millimeters (mm).



# BOARD & BATTEN

Ultra-Premium Vertical Vinyl Siding

## HISTORICAL CHARACTER

Board & Batten's unique vertical design marries historical appeal with modern practicality. Featuring an authentically proportioned 7" exposure with a 5-1/2" board and 1-1/2" batten strip, this ultra-premium panel works well as a whole-house exterior or as an accent siding.

House shown in Dover Gray.



### Product Specifications:

**Nominal Thickness:** .048"  
**Windload:** Laboratory tested to withstand windloads up to 180 km/h (112 mph)  
**Texture:** Light Roughsawn

### 7" Vertical Board & Batten

1/2" Batten Height (12.7)  
 1-1/2" Batten Width (38.1)  
 7" Exposure per Panel (178.5)  
 10' Lengths (3048)

### Packaging:

17 pcs. per ctn.  
 1 sq. per ctn. (9.2 m<sup>2</sup>)  
 Ship. wt: 50 lb (23 kg)

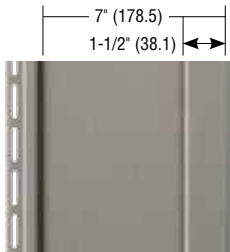

### Classic Colours

Snow White	Wicker	Dover Gray
Sandstone	Canyon Clay	Storm
Linen	Pebble	Chesapeake Gray
Almond	Monterey Sand	Sage
Maize	Pearl	Juniper Grove

### Designer Colours (not available in British Columbia and Alberta)

Majestic Brick	Meadow Fern	Marine Dusk
Dark Drift	Moonlit Moss	Hudson Slate
Rockport Brown	Rockwell Blue	Windswept Smoke
Espresso	Coastal Blue	Iron Ore
Smoked Timber	Midnight Surf	

### Variegated Colours

Aspen	Willow
Earthen	Rainforest



### Warranty Coverage:

Lifetime Limited Warranty  
 Lifetime Limited Fade Coverage  
 Lifetime Limited Hail Coverage



**FAIROAKS**<sup>®</sup>  
Premium Vinyl Siding

## HIGH-PERFORMANCE INNOVATIONS

With exquisite colours and an authentic hardwood texture, Fair Oaks captures the timeless appeal of freshly painted wood. Its rolled nail hem, \* Anchor-Tite™ Locking System, .044" panel thickness and extra-deep 5/8" butt height together achieve quality and strength beyond ordinary vinyl siding.

House shown in Rockwell Blue.



### Product Specifications:

**Nominal Thickness:** .044"  
**Windload:** Laboratory tested to withstand windloads up to 320 km/h (199 mph)\*\*  
**Texture:** Hardwood

\*\*Windload performance may vary by profile design.

### Classic Colours

Snow White	Wicker	Dover Gray
Sandstone	Canyon Clay	Storm
Linen	Pebble	Chesapeake Gray
Almond	Monterey Sand	Sage
Maize	Pearl	Juniper Grove

### Designer Colours

Dark Drift*	Meadow Fern*	Rockwell Blue*
-------------	--------------	----------------

\*Available in Double 4" Clapboard and Double 4" Dutch Lap only. Single 8" is available in Snow White and Maize only.

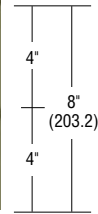

### Double 4" Clapboard

5/8" Butt (15.9)  
2-4" Exposure per Panel (101.6/203.2)  
12'6" Lengths (3810)

**Packaging:**  
24 pcs. per ctn.  
2 sqs. per ctn. (18.6 m<sup>2</sup>)  
Ship. wt: 99 lb (45 kg)

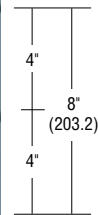

### Double 4" Dutch Lap

5/8" Butt (15.9)  
2-4" Exposure per Panel (101.6/203.2)  
12'6" Lengths (3810)

**Packaging:**  
24 pcs. per ctn.  
2 sqs. per ctn. (18.6 m<sup>2</sup>)  
Ship. wt: 99 lb (45 kg)

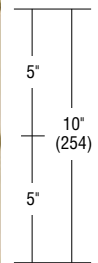

### Double 5" Clapboard

5/8" Butt (15.9)  
2-5" Exposure per Panel (127/254)  
12' Lengths (3658)

**Packaging:**  
20 pcs. per ctn.  
2 sqs. per ctn. (18.6 m<sup>2</sup>)  
Ship. wt: 91 lb (41 kg)

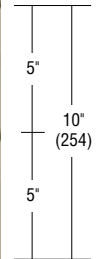

### Double 5" Dutch Lap

5/8" Butt (15.9)  
2-5" Exposure per Panel (127/254)  
12' Lengths (3658)

**Packaging:**  
20 pcs. per ctn.  
2 sqs. per ctn. (18.6 m<sup>2</sup>)  
Ship. wt: 91 lb (41 kg)



### Single 8"

5/8" Butt (15.9)  
8" Exposure per Panel (203.2)  
12'6" Lengths (3810)

**Packaging:**  
24 pcs. per ctn.  
2 sqs. per ctn. (18.6 m<sup>2</sup>)  
Ship. wt: 97 lb (44 kg)

\*Single 8" has a standard nail hem.



**Warranty Coverage:**  
Lifetime Limited Warranty  
Lifetime Limited Fade Coverage  
Lifetime Limited Hail Coverage



# CONCORD®

Quality Vinyl Siding

## TIMELESS QUALITY AND STYLE

Featuring five versatile profiles embossed with a light roughsawn texture, Concord is a longtime favourite among homeowners who desire the beauty of a freshly painted wood finish but without the time-consuming maintenance. The well-built panel is fortified with a rolled nail hem for extra-strong wall attachment and durability.

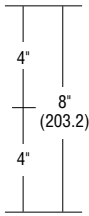

### Double 4" Clapboard

1/2" Butt (12.7)  
2-4" Exposure per Panel (101.6/203.2)  
12'6" Lengths (3810)

**Packaging:**  
24 pcs. per ctn.  
2 sqs. per ctn. (18.6 m<sup>2</sup>)  
Ship. wt: 94 lb (43 kg)

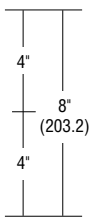

### Double 4" Dutch Lap

1/2" Butt (12.7)  
2-4" Exposure per Panel (101.6/203.2)  
12'6" Lengths (3810)

**Packaging:**  
24 pcs. per ctn.  
2 sqs. per ctn. (18.6 m<sup>2</sup>)  
Ship. wt: 94 lb (43 kg)

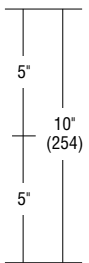

### Double 5" Clapboard

1/2" Butt (12.7)  
2-5" Exposure per Panel (127/254)  
12' Lengths (3658)

**Packaging:**  
20 pcs. per ctn.  
2 sqs. per ctn. (18.6 m<sup>2</sup>)  
Ship. wt: 91 lb (41 kg)

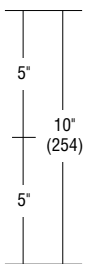

### Double 5" Dutch Lap

1/2" Butt (12.7)  
2-5" Exposure per Panel (127/254)  
12' Lengths (3658)

**Packaging:**  
20 pcs. per ctn.  
2 sqs. per ctn. (18.6 m<sup>2</sup>)  
Ship. wt: 90 lb (41 kg)

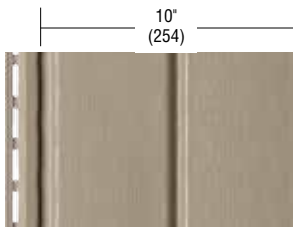

### 10" Vertical

10" Exposure per Panel (254)  
10' Lengths (3048)

**Packaging:**  
24 pcs. per ctn.  
2 sqs. per ctn. (18.6 m<sup>2</sup>)  
Ship. wt: 83 lb (38 kg)



House shown in Pearl.



### Product Specifications:

**Nominal Thickness:** .042"  
**Windload:** Laboratory tested to withstand windloads up to 310 km/h (193 mph)\*  
**Texture:** Light Roughsawn

### Classic Colours

Snow White	Wicker	Dover Gray
Sandstone	Canyon Clay	Storm
Linen	Pebble	Chesapeake Gray
Almond	Monterey Sand	Sage
Maize	Pearl	Juniper Grove



**Warranty Coverage:**  
Lifetime Limited Warranty  
Lifetime Limited Fade Coverage  
Lifetime Limited Hail Coverage

\*Windload performance may vary by profile design. Please see detailed product directory for accessory information. For metric, unless indicated otherwise, all measurements are in millimeters (mm).



# DRIFTWOOD® II

Quality Vinyl Siding

## INSPIRATION FOR EASY LIVING

From classic to modern, Driftwood II combines eye-catching style with everyday affordability. The low-gloss finish, natural cedargrain texture and rich palette of colours will beautifully showcase the architectural details of any home, while the rolled nail hem and quality construction deliver durability and strength.

QUALITY

House shown in Pebble.



### Product Specifications:

**Nominal Thickness:** .040"  
**Windload:** Laboratory tested to withstand windloads up to 283 km/h (176 mph)\*  
**Texture:** Natural Cedargrain

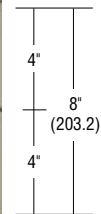

**Double 4" Clapboard**  
 7/16" Butt (11.1)  
 2-4" Exposure per Panel (101.6/203.2)  
 12'6" Lengths (3810)

**Packaging:**  
 24 pcs. per ctn.  
 2 sqs. per ctn. (18.6 m<sup>2</sup>)  
 Ship. wt: 82 lb (37.65 kg)

### Classic Colours

Snow White	Canyon Clay	Storm
Sandstone	Pebble	Chesapeake Gray
Linen	Monterey Sand	Sage
Almond	Amber	Juniper Grove
Maize	Pearl	
Wicker	Dover Gray	

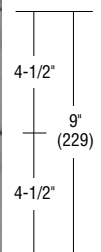

**Double 4-1/2" Dutch Lap**  
 7/16" Butt (11.1)  
 2-4-1/2" Exposure per Panel (114/229)  
 12' Lengths (3658)

**Packaging:**  
 22 pcs. per ctn.  
 2 sqs. per ctn. (18.6 m<sup>2</sup>)  
 Ship. wt: 79 lb (35.83 kg)



**Warranty Coverage:**  
 Lifetime Limited Warranty  
 Lifetime Limited Fade Coverage  
 Lifetime Limited Hail Coverage



# ADVANTAGE<sup>®</sup> III

Premium Vinyl Siding

## CLEAN-LINE DESIGN

Advantage III presents a refreshing combination of elegance and strength. Exquisitely detailed with a subtle brushed texture, its clean-lined triple 3" exposure and bold shadow lines will lend a generous measure of dimension and style to any home.

House shown in Snow White.



### Product Specifications:

**Nominal Thickness:** .042"  
**Windload:** Laboratory tested to withstand windloads up to 249 km/h (155 mph)  
**Texture:** Brushed

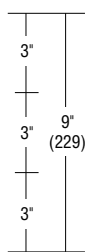

### Triple 3" Clapboard

1/2" Butt (12.7)  
 3-3" Exposure per Panel (76.2/229)  
 12'1" Lengths (3683)

**Packaging:**  
 22 pcs. per ctn.  
 2 sqs. per ctn. (18.6 m<sup>2</sup>)  
 Ship. wt: 96 lb (44 kg)

### Classic Colours

Snow White	Wicker	Dover Gray
Sandstone	Canyon Clay	Storm
Linen	Pebble	Chesapeake Gray
Almond	Monterey Sand	Sage
Maize	Pearl	Juniper Grove



**Warranty Coverage:**  
 Lifetime Limited Warranty  
 Lifetime Limited Fade Coverage  
 Lifetime Limited Hail Coverage

Please see detailed product directory for accessory information. For metric, unless indicated otherwise, all measurements are in millimeters (mm).



# BERKSHIRE<sup>™</sup> BEADED

Premium Vinyl Siding

## FOREVER IN STYLE

Beautifully traditional, Berkshire Beaded recreates the beloved old-world charm of colonial siding. The gracefully sculpted beaded ridge and inviting shadow lines of its 6-1/2" profile offer a modern take on historical craftsmanship.

House shown in Dover Gray.



### Product Specifications:

**Nominal Thickness:** .042"  
**Windload:** Laboratory tested to withstand windloads up to 280 km/h (174 mph)  
**Texture:** Brushed

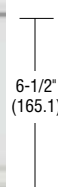

### 6-1/2" Beaded

3/4" Butt (19)  
 6-1/2" Exposure per Panel (165.1)  
 12'3-3/4" Lengths (3753)

**Packaging:**  
 30 pcs. per ctn.  
 2 sqs. per ctn. (18.6 m<sup>2</sup>)  
 Ship. wt: 102 lb (46 kg)

### Classic Colours

Snow White	Wicker	Dover Gray
Sandstone	Canyon Clay	Storm
Linen	Pebble	Chesapeake Gray
Almond	Monterey Sand	Sage
Maize	Pearl	Juniper Grove



**Warranty Coverage:**  
 Lifetime Limited Warranty  
 Lifetime Limited Fade Coverage  
 Lifetime Limited Hail Coverage



# SHAKES AND SHINGLES

## MAKE A STATEMENT OF STYLE

Our superb collection of shakes and shingles combines the best of both worlds – the beauty of nature and the power of technology. The authentic profile designs and authentic textures achieve the character and charm of handcrafted wood in a high-performance polymer construction.



### Colour Palette

Snow White	Dover Gray	Meadow Fern
Sandstone	Storm	Moonlit Moss
Linen	Chesapeake Gray	Rockwell Blue
Almond	Sage	Coastal Blue
Maize	Juniper Grove	Midnight Surf
Wicker	Majestic Brick	Marine Dusk
Canyon Clay	Dark Drift	Hudson Slate
Pebble	Rockport Brown	Windswept Smoke
Monterey Sand	Espresso	Iron Ore
Pearl	Smoked Timber	

Not all colours available in all profiles; see your Gentek representative for details.



**GRAYNE**  
ENGINEERED SHAKES & SHINGLES

Grayne Engineered Composite Shingles replicate the organic look of cedar with realistic texture and sharp, crisp edges.

### 5" Colour Palette

Cape Grey	Autumn Shade	Lakeside Blue
Ridge Moss	Aspen Brown	Homestead Red

### 7-1/2" Colour Palette

Mountain Ash	Rustic Slate	Treated Cedar
Aged Grey	Harvest Shade	Heritage Grey



Split Shake    Staggered Shake    Round Shingle    Perfection Shingle

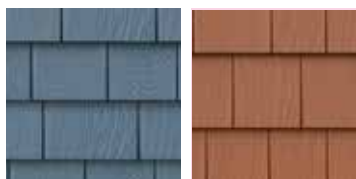

5" White Cedar Shingle    7-1/2" Red Cedar Shingle

# DELUXE™

ALUMINUM SIDING

## CLASSIC BEAUTY AND APPEAL

Masterfully crafted with attention to detail, the classic profile designs and smooth texture of Deluxe aluminum siding will impart casual elegance to any architectural style. The tough aluminum core and resilient Poly finish provide a durable, weathertight exterior that never needs to be painted.

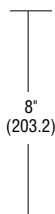

### 8" Horizontal

1/2" Butt (12.7)  
8" Exposure per Panel (203.2)  
12'6" Lengths (3810)

#### Packaging:

24 pcs. per ctn.  
2 sqs. per ctn. (18.6 m<sup>2</sup>)  
Ship. wt: 75.55 lb (34.27 kg)

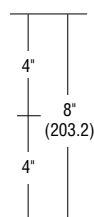

### Double 4" Clapboard

1/2" Butt (12.7)  
2-4" Exposure per Panel (101.6/203.2)  
12'6" Lengths (3810)

#### Packaging:

24 pcs. per ctn.  
2 sqs. per ctn. (18.6 m<sup>2</sup>)  
Ship. wt: 65.39 lb (29.66 kg)

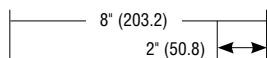
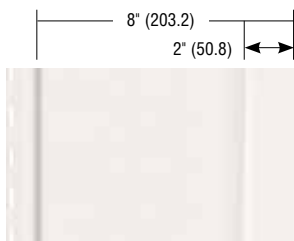

### 8" Vertical Board & Batten

8" Exposure per Panel (203.2)  
10' Lengths (3048)

#### Packaging:

15 pcs. per ctn.  
1 sq. per ctn. (9.29 m<sup>2</sup>)  
Ship. wt: 35.6 lb (16.15 kg)

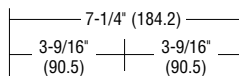

### Vertical "V"

7-1/4" Exposure per Panel (184.2)  
9'7-3/8" Lengths (2930)

#### Packaging:

17 pcs. per ctn.  
1 sq. per ctn. (9.29 m<sup>2</sup>)  
Ship. wt: 30.95 lb (14.04 kg)

Note: Also available in a heavy-gauge profile.



House shown in Bright White.



Texture: Smooth

### Colour Palette

Bright White	Wicker	Dover Gray
Ice White	Canyon Clay	Slate
Sandstone	Pebble	Forest Green
Cashmere	Tan	Chestnut Brown
Almond	Sandalwood	Commercial Brown
Maize	Sable	Black

Not all colours available in all profiles. For specific colour offering, see matrix on page 43.



**Warranty Coverage:**  
40 Year Limited Warranty

Please see detailed product directory for accessory information.  
For metric, unless indicated otherwise, all measurements are in millimeters (mm).

# WOODGRAIN™ 2000

ALUMINUM SIDING

## VERSATILE PROFILES

Warm and welcoming, Woodgrain 2000 combines the traditional beauty of hand-cut wood siding with the high-performance properties of aluminum. Each heavy-duty panel is coated with a specially formulated Poly finish to create a resilient exterior that will maintain its beautiful appearance year after year despite exposure to harsh weather elements.

PREMIUM



House shown in Bright White.

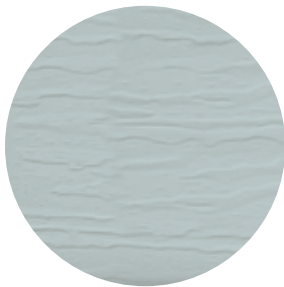

Texture: Woodgrain

### Colour Palette

Bright White	Canyon Clay	Slate
Ice White	Pebble	Forest Green
Sandstone	Tan	Burgundy
Cashmere	Sandalwood	Chestnut Brown
Almond	Dark Drift	Commercial Brown
Maize	Sable	Black
Wicker	Dover Gray	

Not all colours available in all profiles. For specific colour offering, see matrix on page 43.

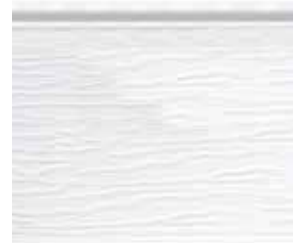

**8" Horizontal**  
1/2" Butt (12.7)  
8" Exposure per Panel (203.2)  
12'6" Lengths (3810)

**Packaging:**  
24 pcs. per ctn.  
2 sqs. per ctn. (18.58 m<sup>2</sup>)  
Ship. wt: 75.55 lb (34.27 kg)



**Double 4" Clapboard**  
1/2" Butt (12.7)  
2-4" Exposure per Panel (101.6/203.2)  
12'6" Lengths (3810)

**Packaging:**  
24 pcs. per ctn.  
2 sqs. per ctn. (18.58 m<sup>2</sup>)  
Ship. wt: 59.32 lb (26.91 kg)



**Double 4" Dutch Lap**  
1/2" Butt (12.7)  
2-4" Exposure per Panel (101.6/203.2)  
12'6" Lengths (3810)

**Packaging:**  
24 pcs. per ctn.  
2 sqs. per ctn. (18.58 m<sup>2</sup>)  
Ship. wt: 59.32 lb (26.91 kg)

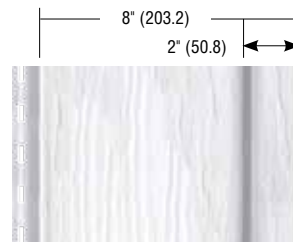

**8" Vertical Board & Batten**  
8" Exposure per Panel (203.2)  
10' Lengths (3048)

**Packaging:**  
15 pcs. per ctn.  
1 sq. per ctn. (9.29 m<sup>2</sup>)  
Ship. wt: 35.6 lb (16.15 kg)

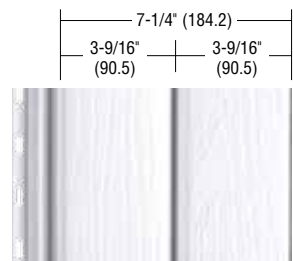

**Vertical "V"**  
7-1/4" Exposure per Panel (184.2)  
9'7-3/8" Lengths (2930)

**Packaging:**  
17 pcs. per ctn.  
1 sq. per ctn. (9.29 m<sup>2</sup>)  
Ship. wt: 30.91 lb (14.02 kg)

Note: D4 Dutch and 7-1/4" Vertical "V" also are available in a heavy-gauge profile.



**Warranty Coverage:**  
40 Year Limited Warranty

# Distinction

Architectural Steel Siding

## HIGH-PERFORMANCE STEEL SIDING WITH VARIEGATED WOOD BEAUTY

In Distinction siding, you have found a premier exterior cladding that beautifully merges the protective strength of steel with the organic visual appeal of wood. The 12" panel system features a pre-notched anchor band and concealed fasteners for installation ease.



Design-inspired and impeccably crafted, Distinction siding adds value and elegance to any home by wrapping the exterior in a robust steel shield.

- Heavy-duty 26 gauge steel construction
- Premium paint system over G90 galvanized steel or Galvalume provides long-term durability and rust prevention
- Resilient, UV-resistant paint prevents discolouration and cracking
- Installs vertically or horizontally; panels lock together on four sides
- Choose from a variety of colours in the Wood Series, Nuanced Wood Series or Granite Series



**ALUMINUM PANELS WITH RICH WOOD BEAUTY**

Realistic-looking woodgrain finishes and colours make Longboard a standout selection for upscale residential applications. This high-performance cladding recreates the natural beauty and richness of wood but without the maintenance.



- Available in 24' lengths and a large selection of woodgrain finishes and powder-coated colours
- Anti-graffiti coating
- Won't rot, warp, peel or fade
- Up to 25% recycled content and 100% recyclable



Dark Knotty Pine



Dark Fir



Dark Antique Oak



Dark Cherry



Light National Walnut



Table Walnut



## CHAMCLAD PVC SIDING, SOFFIT, CEILING AND TRIM

Lightweight and strong, ChamClad's impact-resistant, non-fading PVC panels provide beautiful architectural options for a wide range of applications, inside and out.

Exclusively at  
**GENTEK**



- Made in Canada from 100% recycled PVC; LEED compliant
- V-groove and U-channel profiles embedded into the same profile
- Stay-true colours; UV-protectant coat shields against fading
- Easy installation – no special tools or caulking required
- One of the most realistic finishes on the market
- Wide range of colours, trim and accessories are available



Additional colours available.



# Versetta Stone™

The beauty of stone, the simplicity of siding™

## THE SIGNATURE LOOK OF STONE

Create the high-end style of traditional stone masonry but without the excess cost and installation time. Versetta Stone combines handcrafted beauty with modern practicality in a non-structural, cement-based panelized stone veneer.

**INTERIOR  
EXTERIOR  
APPLICATIONS**



- Cast in moulds and hand-coloured with iron oxide pigments to replicate natural stone shapes, textures and patterns
- Lightweight and easy to install with tongue and groove interlocking system; installs in any weather
- Designed to effectively manage moisture to help prevent mold growth
- Ideal for exteriors, interiors, new construction and remodel projects
- Tested and approved to rigorous building standards
- NAHB Green Approved Product

Choose from LedgeStone or Tight-Cut profiles in a variety of colours.



LedgeStone panel shown in Plum Creek.



Tight-Cut panel shown in Sterling.



Plum Creek



Graphite



Sterling



Mission Point



Terra Rosa



Northern Ash



## THE AUTHENTIC LOOK AND FEEL OF CEDAR

With superior dimensional strength and durability, Everlast's triple-composite extruded planks achieve the perfect mix of natural beauty and rugged construction.



- Available in 4-1/2" Clapboard, 6-7/8" Clapboard and Vertical Board & Batten profiles in 12' length planks
- Low-gloss CedarTouch® texture recreates the look and feel of genuine cedar
- Proprietary triple composite of polymer resins, inorganic minerals and acrylic colourants
- Innovative co-extruded panel provides UV-stable colour cap with outstanding fade resistance
- Naturally water-resistant and contains no wood fibers or organic materials; resists rotting, cracking and insect damage
- Superior wind, hail and impact resistance; Everlast panels do not support combustion
- Lightweight construction and installation ease – the composite material cuts just like wood but without the dust







**James Hardie®**

**FOR EVERY HOME, EVERY STYLE**

Featuring a wide variety of textures and profiles, this sleek, strong and non-combustible fiber cement panel offers custom-crafted design appeal for any style home.

DESIGNER



- Beautiful, durable and highly weather-resistant
- ColorPlus® Technology for long-lasting colour
- Engineered for Climate® to meet specific climate demands
- HardieTrim Boards available in smooth and woodgrain textures, batten boards and crown moulding



HardiePlank Lap Siding  
Select Cedarmill

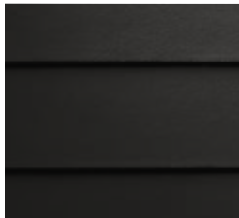

HardiePlank Lap Siding  
Smooth

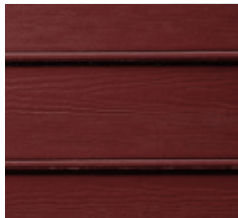

HardiePlank Lap Siding  
Beaded Cedarmill



HardiePlank Lap Siding  
Beaded Smooth



HardieShingle Siding  
Staggered Edge Panel

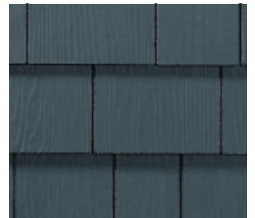

HardieShingle Siding  
Straight Edge Panel

**Product Specifications:**

**Windload:** Laboratory tested to withstand windloads up to 257 km/h (160 mph).

**Texture:** Roughsawn  
12' Vertical Board & Batten is  
Medium Woodgrain Texture

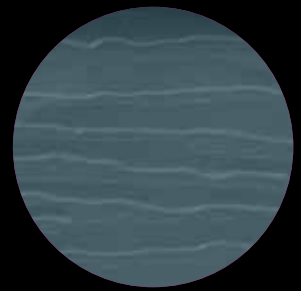

**Colour Palette**

Bright White	Dover Gray
Chelsea Bluff	Storm
Monterey Sand	Iron Ore
Delray Sand	Rockwell Blue
Thistle	Watermill Blue
Sable	Taylor Red
Juniper Grove	

**Impact Resistant** Constructed of roll-formed 29 gauge Galvalume AZ-50 steel for maximum resistance to hail damage and denting.

**Built Weather-Tough** Rugged steel construction is virtually impervious to outdoor elements. Unlike wood, compressed particleboard or fiber cement, it won't absorb moisture. Steel siding also resists warping, chalking, fading and brittleness in cold weather; independently tested to withstand hurricane-force winds, with wind speed exceeding 257 km/h (160 mph).

**Smooth, Straight Wall Lines** Rigid steel panels deliver high dimensional stability and resist buckling and the wavy appearance that can result from expansion and contraction caused by extreme weather changes.

**Upscale Appearance** Deep 1/2" panel projection creates greater dimension and style with bold edges and dramatic shadow lines. The resilient PVDF finish resists dirt and dust buildup, staining and mildew.

**Carefree Maintenance** No need for time-consuming painting or scraping. Just a simple rinse with a garden hose will remove most airborne dust and dirt.

**Environmentally Friendly!** Steel siding is 100% recyclable, requires no additional painting or caulking and does not produce silica dust during installation.

**Insect Resistant** Resists damage from wood-eating insects, such as termites.

# LUXURY'S NEW LOOK – THE BEAUTIFUL STRENGTH OF STEEL

Distinguished for its superb durability and versatile design possibilities, metal is on the rise as a prime exterior cladding. Premium raw materials and cutting-edge technology merge with skilled craftsmanship and artistry to achieve the outstanding quality of our Sierra Steel siding. Each panel is virtually “weather-sealed” with a resilient Kynar PVDF coating, a high-performance fluoropolymer resin with a luxurious low-gloss finish.



House shown in Iron Ore.

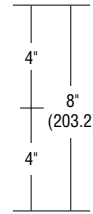

### Double 4" Clapboard

1/2" Butt (12.7)  
2-4" Exposure per Panel (101.6/203.2)  
12'6" Lengths (3810)

**Packaging:**  
10 pcs. per ctn.  
1 sq. per ctn. (9.29 m<sup>2</sup>)  
Ship. wt: 91 lb (41 kg)

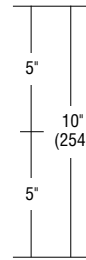

### Double 5" Clapboard

1/2" Butt (12.7)  
2-5" Exposure per Panel (127/254)  
10' Lengths (3048)

**Packaging:**  
10 pcs. per ctn.  
1 sq. per ctn. (9.29 m<sup>2</sup>)  
Ship. wt: 85 lb (39 kg)

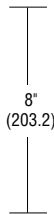
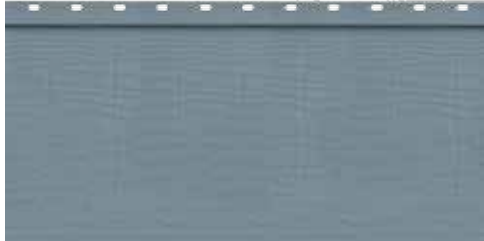

### 8" Horizontal

1/2" Butt (12.7)  
8" Exposure per Panel (203.2)  
12'6" Lengths (3810)

**Packaging:**  
12 pcs. per ctn.  
1 sq. per ctn. (9.29 m<sup>2</sup>)  
Ship. wt: 91 lb (41 kg)

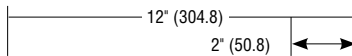

### 12" Vertical Board & Batten

5/8" Batten Height (15.9)  
2" Batten Width (50.8)  
12" Exposure per Panel (304.8)  
10' Lengths (3048)

**Packaging:**  
10 pcs. per ctn.  
1 sq. per ctn. (9.29 m<sup>2</sup>)  
Ship. wt: 85 lb (39 kg)



**Warranty Coverage:**  
Lifetime Limited Warranty  
50 Year Hail Protection  
35 Year Chalk and Colour Change Protection

Please see detailed product directory for accessory information. For metric, unless indicated otherwise, all measurements are in millimeters (mm).

# SOFFIT AND FASCIA SYSTEMS

## VINYL SOFFIT SYSTEMS

Performance-engineered for enduring beauty, soffit and fascia add the perfect finishing touch to rooflines, gables and trim while providing essential ventilation that removes moisture from eaves and rafters.



12" T-4 Solid Soffit/  
Vertical Siding

12" T-4 Vented

### Sequoia Select Ultra-Premium

12" T-4  
Nominal Thickness: .044"  
Texture: Matte  
12" Exposure per Panel (304.8)  
12' Lengths (3658)  
Hidden dual vent slots  
10 sq. in. ventilation per lineal ft.

#### Packaging:

16 pcs. per ctn.  
1.92 sqs. per ctn. (17.8 m<sup>2</sup>)  
Ship. wt: 109.2 lb (49.53 kg)



10" D-5 Solid Soffit/  
Vertical Siding

10" D-5  
Fully Vented

### Oxford Premium

10" D-5  
Nominal Thickness: .042"  
Texture: Light Roughsawn  
10" Exposure per Panel (254)  
12' Lengths (3658)  
5.3 sq. in. ventilation per lineal ft.

#### Packaging:

20 pcs. per ctn.  
2 sqs. per ctn. (18.6 m<sup>2</sup>)  
Ship. wt: 83 lb (38 kg)

Oxford Premium solid profile is also available in 10' lengths.  
Note: EZ Lock 10" D-5 solid and vented soffit is offered in Snow White, Linen, Wicker and Black.



8" Solid Soffit

8" Vented

### Beaded Premium

8" Panel  
Nominal Thickness: .042"  
Texture: Matte  
8" Exposure per Panel (203.2)  
12' 6" Lengths (3810)  
2.4 sq. in. ventilation per lineal ft.

#### Packaging:

12 pcs. per ctn.  
1 sq. per ctn. (9.29 m<sup>2</sup>)  
Ship. wt: 59 lb (27 kg)



12" T-4 Solid Soffit/  
Vertical Siding

12" T-4  
Centre Vented

### Fairweather

12" T-4  
Nominal Thickness: .040"  
Texture: Brushed  
12" Exposure per Panel (304.8)  
12' Lengths (3658)  
Center Vented = 2.3 sq. in. ventilation per lineal ft.  
Fully Vented = 7.1 sq. in. ventilation per lineal ft.

#### Packaging:

16 pcs. per ctn.  
1.92 sqs. per ctn. (17.8 m<sup>2</sup>)  
Ship. wt: 79 lb (36 kg)

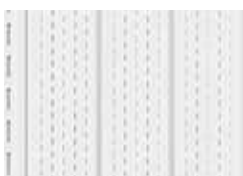

12" T-4  
Fully Vented



### Classic Colours

Snow White	Monterey Sand
Sandstone	Pearl
Linen	Dover Gray
Almond	Storm <sup>†</sup>
Maize	Chesapeake Gray <sup>†</sup>
Wicker	Sage
Canyon Clay	Juniper Grove
Pebble	

### Designer Colours

Musket Brown	Black <sup>††</sup>
--------------	---------------------

Beaded Premium is available in Snow White, Linen, Wicker, Canyon Clay, Pebble, Sandalwood, Monterey Sand and Juniper Grove only.

<sup>†</sup>Available in Oxford Premium and Fairweather soffit only.

<sup>††</sup>Available in Oxford Premium and EZ Lock soffit only.

# ALUMINUM SOFFIT AND FASCIA

Gentek aluminum soffit panels features a distinctive V-groove design for extra strength and rigidity, and lock together easily for a fast, professional finish.

## Classic Colours

Bright White	Storm
Rainware White	Chesapeake Gray
Ice White	Slate
Sandstone	Sage
Cashmere	Ivy Green
Almond	Forest Green
Maize	Wedgewood Blue
Wicker	Old World Blue
Canyon Clay	AluCopper
Pebble	Bright Red
Sandalwood	Burgundy
Monterey Sand	Nutmeg
Tan	Chestnut Brown
Brownstone	Commercial Brown
Sable	Antique Brown
Metallic Gray	Graphite
Dover Gray	Black

## Designer Colours

Majestic Brick	Midnight Surf
Dark Drift	Marine Dusk
Rockport Brown	Meadow Fern
Espresso	Moonlit Moss
Smoked Timber	Hudson Slate
Rockwell Blue	Windswept Smoke
Coastal Blue	Iron Ore

Not all products and colours are available at all locations. Please check with your local Gentek branch for product availability.



16" 2-Panel Solid

16" 2-Panel Vented

### 16" 2-Panel Soffit

Available in Heavy Gauge and Standard Gauge  
Texture: Smooth  
16" Exposure per Panel (406)  
12'1"-15'16" Lengths (3708)  
4.02 sq. in. ventilation per lineal ft.  
Heavy Gauge, 12 pcs. per ctn.  
Standard Gauge, 18 pcs. per ctn.

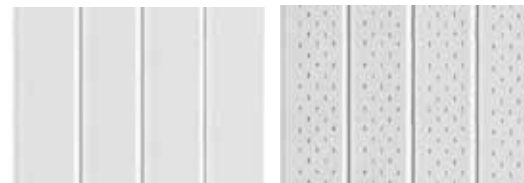

16" 4-Panel Solid

16" 4-Panel Vented

### 16" 4-Panel Soffit

Available in Heavy Gauge and Standard Gauge  
Texture: Smooth  
16" Exposure per Panel (406)  
12'2"-3'8" Lengths (3718)  
4.12 sq. in. ventilation per lineal ft.  
Heavy Gauge, 18 pcs. per ctn.  
Standard Gauge, 18 pcs. per ctn.



18" 3-Panel Solid

18" 3-Panel Vented

### 18" 3-Panel Soffit

Heavy Gauge  
Texture: Smooth  
18" Exposure per Panel (457.2)  
10' Lengths (3048)  
5.46 sq. in. ventilation per lineal ft.  
12 pcs. per ctn.

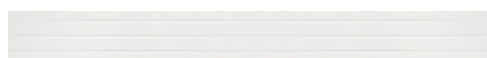

4" Fascia, Ribbed; available in Standard and Economy

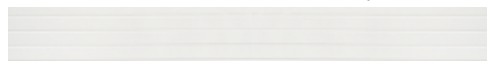

6" Fascia, Ribbed; available in Standard, Economy and Heavy Gauge



8" Fascia, Ribbed; available in Standard and Heavy Gauge

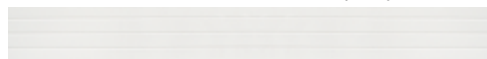

10" Fascia, Ribbed; Standard Gauge

### 4", 6", 8" and 10" Ribbed Fascia

4" (101.6), 6" (152.4), 8" (203.2), 10" (254)

Texture: Smooth  
9'10" Lengths (3000)  
Ribbed

4" fascia, 30 pcs. per ctn.  
6", 8", 10" fascia, 20 pcs. per ctn.

Note: 6" and 8" Fascia also available in Heavy Gauge Ribbed, 20 pcs. per ctn., and Heavy Gauge Plain, 25 pcs. per ctn.

# RAINWARE PRODUCTS

## A QUALITY FINISH FROM EVERY ANGLE

Built of corrosion-resistant aluminum, Gentek rainware products will not rot, rust or warp. A tough, baked-on paint finish resists flaking, peeling and blistering to ensure years of maintenance-free performance.

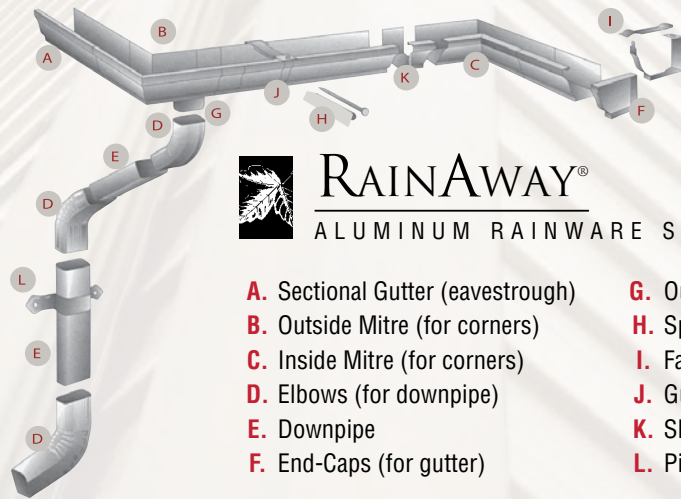
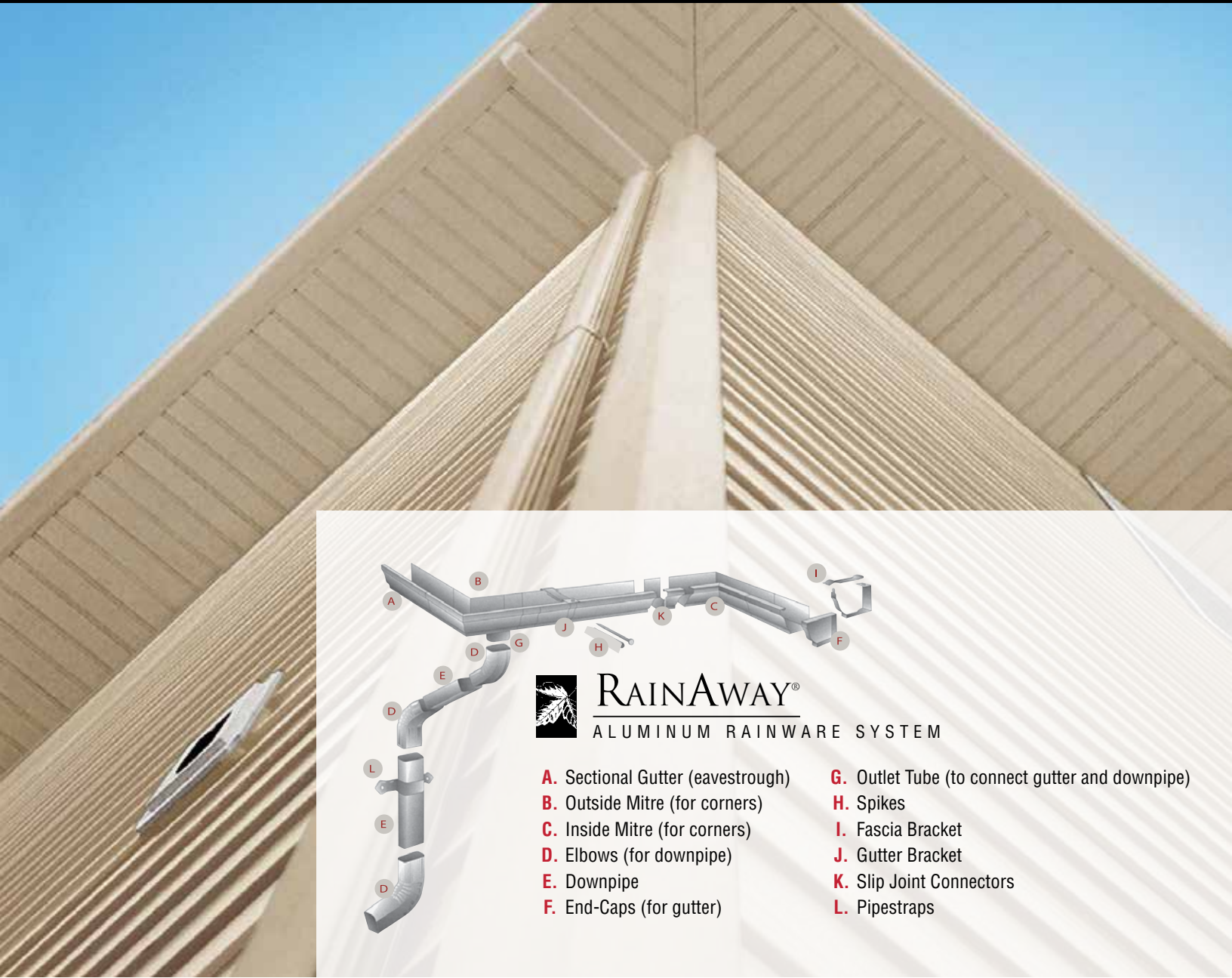

**RAINAWAY®**  
ALUMINUM RAINWARE SYSTEM

- A.** Sectional Gutter (eavestrough)
- B.** Outside Mitre (for corners)
- C.** Inside Mitre (for corners)
- D.** Elbows (for downpipe)
- E.** Downpipe
- F.** End-Caps (for gutter)
- G.** Outlet Tube (to connect gutter and downpipe)
- H.** Spikes
- I.** Fascia Bracket
- J.** Gutter Bracket
- K.** Slip Joint Connectors
- L.** Pipestraps

### GUTTER GUARDS

Gentek carries a wide selection of gutter guards, including Alu-Rex quality products.



# BLOCKS, VENTS, SHUTTERS AND COLUMNS

## IMPECCABLE FORM AND FUNCTIONALITY

Our columns, shutters, blocks and vents lend the perfect finishing touch to any home exterior. Masterfully crafted with attention to detail, this ample selection will cover your every design need with a premium finish.





# REGENCY 400 SERIES

VINYL REPLACEMENT WINDOWS

## NEXT-GENERATION ENERGY EFFICIENCY

With meticulous attention to every detail, Regency 400 Series merges modern style with best-in-class technology to achieve superior energy efficiency, enduring beauty, easy upkeep and excellent value.



See your Gentek representative for the optimal insulated glass package for your project and climate conditions.



### SUPERIOR PERFORMANCE IS INHERENT IN THE DESIGN

Energy-engineered Regency 400 Series replacement windows are expertly crafted to improve the energy efficiency of a home while enhancing its appearance with an upscale, contemporary look. The superb construction features an extra-strong 4-1/2" thick fusion-welded frame with the sash positioned closer to the interior part of the wall for increased thermal protection.

- Heavy-duty 4-1/2" welded rigid vinyl multi-chamber frame construction
- Welded sashes with triple weatherstripping for superior insulation
- 7/8" thick double-glazed glass units with Low-E, argon and Super Spacer® structural foam spacer (standard)
- Triple-glazed units up to 1-3/8" thick Low-E and argon or krypton for ultra energy efficiency (optional)
- EnergyPlus™ and Solar Shield glass packages available
- Environmentally friendly – designed for superior thermal performance and a smaller carbon footprint
- Contemporary sash for a modern look



### Frame Colours

Nordic White – extruded	Dover Gray
Cream	Storm
Almond	Slate
Maize	Windswept Smoke
Wicker	Chestnut Brown
Canyon Clay	Commercial Brown
Pebble	Espresso
Sandalwood	Graphite
Brownstone	Iron Ore
Dark Drift	Black
Sable	

- Choose from extruded Nordic White, 20 standard exterior paint colours and a variety of custom hues
- Decorative grids, specialty glass and installation accessories







Regency®

HIGH-PERFORMANCE WINDOWS

## ENERGY-SAVING SOLUTIONS DESIGNED FOR NORTHERN CLIMATES

For many homeowners, conserving energy and reducing fuel costs is a primary reason for purchasing new windows – and that’s why maximum thermal efficiency is at the core of our Regency window design.



See your Gentek representative for the optimal insulated glass package for your project and climate conditions.

ULTRA - PREMIUM



### EXCEPTIONAL STRENGTH, ENDURING STYLE

Precision-engineered for outstanding thermal efficiency, Regency windows incorporate several best-in-class features to ensure an exceptionally strong and weathertight fit, as well as advanced energy savings and a markedly refined appearance.

- Fusion-welded masterframe and sash corners
- Beveled exterior masterframe accommodates various installation methods and architectural styles
- Metal-reinforced sash
- Double-glazed EnergyPlus glass with Low-E, argon gas and Super Spacer structural foam spacer
- Double- and triple-glazed glass EnergyPlus and Solar Shield glass packages available

### CREATE CUSTOM APPEAL

- Choose from extruded White and Beige, 20 standard exterior paint colours and a variety of custom hues
- Interior colours are extruded White or Beige; an optional Dark Oak laminate is available in select window styles
- Decorative grids and specialty glass
- Jamb extensions, brickmoulds and installation accessories

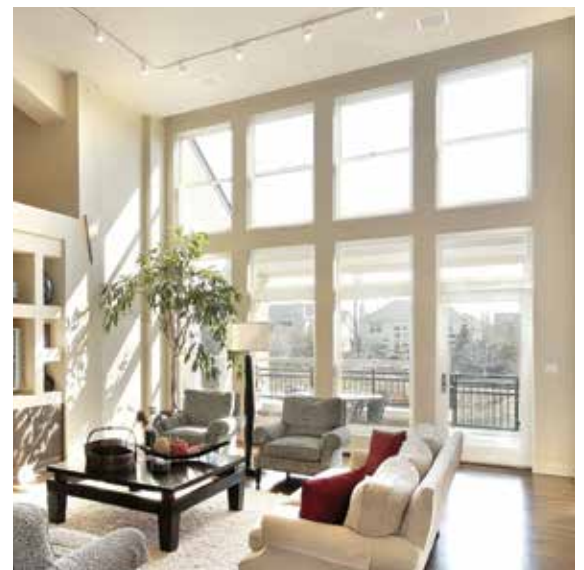

Hopper Window



Basement Window



Awning



Slider



Casement



Double Hung



Single Hung

# 80 Series

FUSION-WELDED VINYL WINDOWS

## DESIGNED FOR YEAR-ROUND ENERGY SAVINGS

Featuring a premium vinyl construction, fusion-welded technology and high-performance glass, 80 Series windows will exceed your every expectation for energy efficiency, quality and value.



See your Gentek representative for the optimal insulated glass package for your project and climate conditions.



Available  
only in  
**WESTERN  
CANADA.**

### STYLISH AND STRONG

In 80 Series, you have discovered a window that will increase the energy efficiency of a home while enhancing its appearance, inside and out. Heavy-duty vinyl frames and sashes, multi-chambered extrusions and high-performance insulating glass achieve outstanding energy efficiency. Together, with its superior durability and structural integrity, this premiere vinyl window is as strong as it is beautiful.

- Fusion-welded frame and sashes
- Sturdy 3-3/8" frame depth
- Also available in 1" set back nail fin and stucco flange options
- 1" thick insulated glass unit with Intercept® warm-edge spacer; optional structural foam spacer
- Side-load sash design (single hung windows) and removable fiberglass screens for easy cleaning
- Metal reinforcement in the meeting rails for increased strength and rigidity
- Choose White, Almond and Desert Clay, or a Bronze exterior with White interior

### INSTALLATION EASE

80 Series windows come standard with a 1-3/8" nail fin. For enhanced appearance and ease of installation, three additional options – 1" set back nail fin, stucco fin and a block frame – also are offered.



1-3/8" Nail Fin (standard)

1" Set Back Nail Fin

Stucco Fin

Block Frame



# 70 Series

FUSION-WELDED VINYL WINDOWS

## IMPRESSIVE PERFORMANCE

Our 70 Series windows will add the perfect touch of refinement to any home with their quality construction, enduring good looks and low-maintenance features.

See your Gentek representative for the optimal insulated glass package for your project and climate conditions.



QUALITY

# AMHERST™

VINYL REPLACEMENT WINDOWS

## ENERGY-SMART AND VALUE-PRICED

Amherst windows combine beauty and energy efficiency with everyday affordability. The fusion-welded masterframe and sashes and high-performance glass system together create a strong thermal barrier against energy loss.

QUALITY



Available  
only in  
**WESTERN  
CANADA.**



## BEAUTIFUL, DURABLE AND ENVIRONMENTALLY FRIENDLY

Gentek 70 Series windows deliver a weathertight fit for increased energy savings year-round, while enhancing the appearance of a home inside and out.

- Fusion-welded vinyl frame and sashes
- 2-5/8" frame depth for multiple applications
- 3/4" thick insulated glass unit
- Intercept spacer or optional structural foam spacer
- Metal reinforcement in the meeting rails for increased strength
- Available in White, Almond and Desert Clay

## QUALITY DESIGN AND CONSTRUCTION

Built in the tradition of quality, Amherst windows deliver impressive performance and energy efficiency, as well as beauty and value.

- Fusion-welded frame and sashes
- Energy HSG insulated glass unit with Intercept spacer system
- Interlocking composite-reinforced sash meeting rails
- Bulb seal at the meeting rails
- Beveled exterior profile and sloped sill
- Available in White and Beige

# FIRST IMPRESSIONS

By Gentek

## CREATE A DRAMATIC FOCAL POINT

A beautiful entry door makes a powerful statement of style for any exterior design. Choose from a wide selection of First Impressions by Gentek entry doors in styles that fit every design and budget.



First Impressions by Gentek doors can be customized with decorative glass and hardware for a distinctive design with custom appeal.

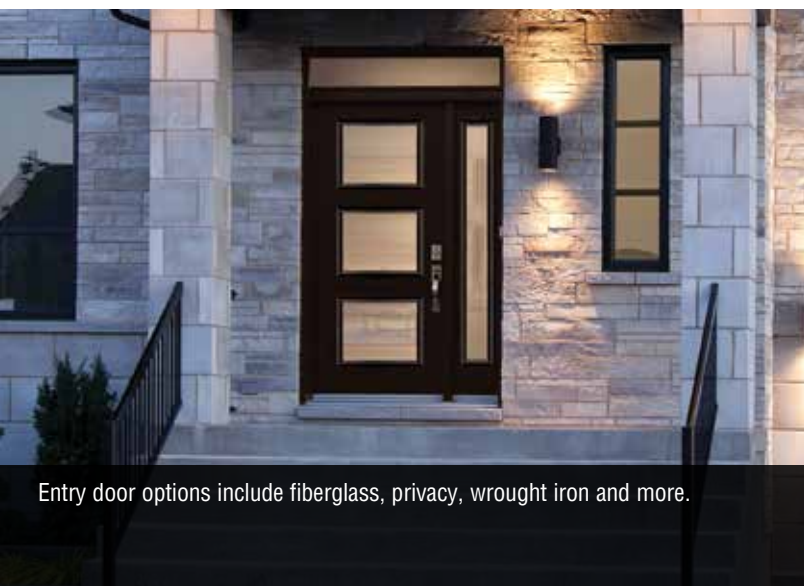

Entry door options include fiberglass, privacy, wrought iron and more.



Our contemporary classics, craftsman and rustic door collections will complement any architectural style.

# PATIO DOORS

## EXPERTLY BUILT FOR SUPERIOR PERFORMANCE

Each door in our versatile collection features a heavy-duty construction, superb design and easy-care features for long-lasting quality and performance.



# STORM DOORS

## PRACTICAL AND STRONG

Gentek offers a full line of expertly crafted storm doors to protect entry areas from inclement weather. Our storm doors also are ideally suited for patio enclosures, providing easy access as well as a substantial weather shield.



# BUILDING ENVELOPE, SEALANTS AND FOAM

Ensure your renovation and new construction projects are securely protected. Our full selection of insulation, sealants and foam provide essential barriers against moisture and air penetration, energy loss and other elements.

## BUILDING ENVELOPE AND INSULATION

Choose from leading brands in building envelope materials, such as Tyvek and HomeGuard housewraps, as well as IKO and Atlas insulation.



## SEALANTS AND FOAM

Finish the job off right with high-quality sealants and foam, such as Mulco® sealants and Rivenco polyurethane foam products and accessories.



# TOOLS AND EQUIPMENT

Having the right tools and equipment for the job is essential for a professional installation. At Gentek, you'll find everything you need, such as Malco® tools, brakes and gutter equipment from Tapco® and Van Mark, and a wide selection of ladders.

## EQUIPMENT

Our full selection of brakes and gutter equipment from Van Mark and Tapco, along with Werner® ladders and scaffolds, makes it easy to get all everything you need in one convenient stop.

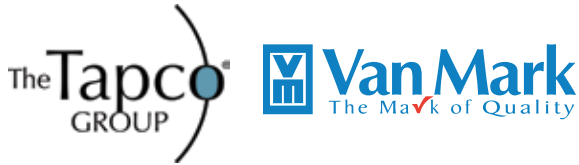

## TOOLS

Gentek carries a wide range of installation tools, including the popular Malco brand, for home exterior renovations and new construction projects.



# SEQUOIA SELECT ENFUSION COLOUR MATRIX

- Available in this colour.

	001 Snow White	632 Almond	010 Canyon Clay	872 Chesapeake Gray	127 Dover Gray	628 Pebble	624 Sage	631 Storm	638 Wicker	655 Dark Drift	873 Hudson Slate	874 Meadow Fern	652 Midnight Surf	653 Moonlit Moss	637 Rockwell Blue	651 Windswept Smoke	Neutral
	Classic Colours									Designer Colours							
<b>Sequoia Select EnFusion</b>																	
Double 5" Dutch Lap	•	•	•	•	•	•	•	•	•	•	•	•	•	•	•	•	
Double 6" Clapboard	•	•	•	•	•	•	•	•	•	•	•	•	•	•	•	•	
<b>Accessories</b>																	
65604 4" Outside Corner Post w/ Foam	•	•	•	•	•	•	•	•	•	•	•	•	•	•	•	•	
65602 Wide Pocket Inside Corner Post	•	•	•	•	•	•	•	•	•	•	•	•	•	•	•	•	
65606 1-1/4" J-Channel	•	•	•	•	•	•	•	•	•	•	•	•	•	•	•	•	
K661945 Easy Start Starter Strip																	•



# VINYL SIDING AND VINYL SOFFIT COLOUR MATRIX

• Available in this colour.

	Classic Colours														Designer Colours											Variegated Colours															
	001 Snow White	632 Almond	616 Amber	010 Canyon Clay	872 Chesapeake Gray	127 Dover Gray	633 Juniper Grove	012 Linen	002 Maize	673 Monterey Sand	006 Pearl	628 Pebble	624 Sage	640 Sandstone	631 Storm	638 Wicker	879 Black	625 Coastal Blue	655 Dark Drift	636 Espresso	873 Hudson Slate	642 Iron Ore	876 Majestic Brick	877 Marine Dusk	874 Meadow Fern	652 Midnight Surf	653 Moonlit Moss	063 Musket Brown	875 Rockport Brown	637 Rockwell Blue	878 Smoked Timber	651 Windswept Smoke	646 Aspen	644 Earthen	645 Rainforest	647 Willow					
<b>Sequoia Select</b>																																									
Double 4" Clapboard	•	•	•	•	•	•	•	•	•	•	•	•	•	•	•	•	•	•	•	•	•	•	•	•	•	•	•	•	•	•	•	•	•	•	•	•	•	•			
Double 4-1/2" Dutch Lap	•	•	•	•	•	•	•	•	•	•	•	•	•	•	•	•	•	•	•	•	•	•	•	•	•	•	•	•	•	•	•	•	•	•	•	•	•	•	•		
Double 5" Clapboard*	•	•	•	•	•	•	•	•	•	•	•	•	•	•	•	•	•	•	•	•	•	•	•	•	•	•	•	•	•	•	•	•	•	•	•	•	•	•	•		
Double 5" Dutch Lap*	•	•	•	•	•	•	•	•	•	•	•	•	•	•	•	•	•	•	•	•	•	•	•	•	•	•	•	•	•	•	•	•	•	•	•	•	•	•	•		
<b>Northern Forest Elite</b>																																									
Double 4" Clapboard																																									
Double 5" Clapboard																																									
Double 5" Dutch Lap																																									
<b>Board &amp; Batten</b>																																									
7" Vertical Board & Batten*	•	•	•	•	•	•	•	•	•	•	•	•	•	•	•	•	•	•	•	•	•	•	•	•	•	•	•	•	•	•	•	•	•	•	•	•	•	•	•		
<b>Fair Oaks</b>																																									
Double 4" Clapboard	•	•	•	•	•	•	•	•	•	•	•	•	•	•	•	•	•	•	•	•	•	•	•	•	•	•	•	•	•	•	•	•	•	•	•	•	•	•	•		
Double 4" Dutch Lap	•	•	•	•	•	•	•	•	•	•	•	•	•	•	•	•	•	•	•	•	•	•	•	•	•	•	•	•	•	•	•	•	•	•	•	•	•	•	•	•	
Double 5" Clapboard	•	•	•	•	•	•	•	•	•	•	•	•	•	•	•	•	•	•	•	•	•	•	•	•	•	•	•	•	•	•	•	•	•	•	•	•	•	•	•	•	
Double 5" Dutch Lap	•	•	•	•	•	•	•	•	•	•	•	•	•	•	•	•	•	•	•	•	•	•	•	•	•	•	•	•	•	•	•	•	•	•	•	•	•	•	•	•	
Single 8"	•	•	•	•	•	•	•	•	•	•	•	•	•	•	•	•	•	•	•	•	•	•	•	•	•	•	•	•	•	•	•	•	•	•	•	•	•	•	•	•	
<b>Concord</b>																																									
Double 4" Clapboard	•	•	•	•	•	•	•	•	•	•	•	•	•	•	•	•	•	•	•	•	•	•	•	•	•	•	•	•	•	•	•	•	•	•	•	•	•	•	•		
Double 4" Dutch Lap	•	•	•	•	•	•	•	•	•	•	•	•	•	•	•	•	•	•	•	•	•	•	•	•	•	•	•	•	•	•	•	•	•	•	•	•	•	•	•	•	
Double 5" Clapboard	•	•	•	•	•	•	•	•	•	•	•	•	•	•	•	•	•	•	•	•	•	•	•	•	•	•	•	•	•	•	•	•	•	•	•	•	•	•	•	•	
Double 5" Dutch Lap	•	•	•	•	•	•	•	•	•	•	•	•	•	•	•	•	•	•	•	•	•	•	•	•	•	•	•	•	•	•	•	•	•	•	•	•	•	•	•	•	
10" Vertical	•	•	•	•	•	•	•	•	•	•	•	•	•	•	•	•	•	•	•	•	•	•	•	•	•	•	•	•	•	•	•	•	•	•	•	•	•	•	•	•	
<b>Driftwood II</b>																																									
Double 4" Clapboard	•	•	•	•	•	•	•	•	•	•	•	•	•	•	•	•	•	•	•	•	•	•	•	•	•	•	•	•	•	•	•	•	•	•	•	•	•	•	•	•	
Double 4-1/2" Dutch Lap	•	•	•	•	•	•	•	•	•	•	•	•	•	•	•	•	•	•	•	•	•	•	•	•	•	•	•	•	•	•	•	•	•	•	•	•	•	•	•	•	•
<b>Advantage III</b>																																									
Triple 3" Clapboard	•	•	•	•	•	•	•	•	•	•	•	•	•	•	•	•	•	•	•	•	•	•	•	•	•	•	•	•	•	•	•	•	•	•	•	•	•	•	•	•	
<b>Berkshire Beaded</b>																																									
6-1/2" Beaded	•	•	•	•	•	•	•	•	•	•	•	•	•	•	•	•	•	•	•	•	•	•	•	•	•	•	•	•	•	•	•	•	•	•	•	•	•	•	•	•	
<b>Vinyl Soffit</b>																																									
Sequoia Select Ultra-Premium 12"	•	•	•	•	•	•	•	•	•	•	•	•	•	•	•	•	•	•	•	•	•	•	•	•	•	•	•	•	•	•	•	•	•	•	•	•	•	•	•	•	
Oxford Premium 10"	•	•	•	•	•	•	•	•	•	•	•	•	•	•	•	•	•	•	•	•	•	•	•	•	•	•	•	•	•	•	•	•	•	•	•	•	•	•	•	•	
Beaded Premium 8"	•	•	•	•	•	•	•	•	•	•	•	•	•	•	•	•	•	•	•	•	•	•	•	•	•	•	•	•	•	•	•	•	•	•	•	•	•	•	•	•	•
Fairweather 12"	•	•	•	•	•	•	•	•	•	•	•	•	•	•	•	•	•	•	•	•	•	•	•	•	•	•	•	•	•	•	•	•	•	•	•	•	•	•	•	•	•
EZ Lock 10"	•	•	•	•	•	•	•	•	•	•	•	•	•	•	•	•	•	•	•	•	•	•	•	•	•	•	•	•	•	•	•	•	•	•	•	•	•	•	•	•	•

\*Designer Colours not available in British Columbia and Alberta.

# VINYL TRIM AND ACCESSORIES COLOUR MATRIX

• Available in this colour.

	Classic Colours																		Designer Colours													Variegated Colours					
	001 Snow White	632 Almond	616 Amber	010 Canyon Clay	872 Chesapeake Gray	127 Dover Gray	633 Juniper Grove	012 Linen	002 Maize	673 Monterey Sand	006 Pearl	628 Pebble	624 Sage	640 Sandstone	631 Storm	638 Wicker	625 Coastal Blue	655 Dark Drift	636 Espresso	873 Hudson Slate	642 Iron Ore	876 Majestic Brick	877 Marine Dusk	874 Meadow Fern	652 Midnight Surf	653 Moonlit Moss	875 Rockport Brown	637 Rockwell Blue	878 Smoked Timber	651 Windswept Smoke	646 Aspen	644 Earthen	645 Rainforest	647 Willow	Neutral		
65504 3-1/2" Outside Corner Post (OCP)	•	•	•	•	•	•	•	•	•	•	•	•	•	•	•	•	•	•	•	•	•	•	•	•	•	•	•	•	•	•							
65524 3-1/2" OCP – Dark Colours																	•	•	•	•	•	•	•	•	•	•	•	•	•	•	•	•	•	•	•	•	•
65501 3" Outside Corner Post	•	•	•	•	•	•	•	•	•	•	•	•	•	•	•	•	•	•	•	•	•	•	•	•	•	•	•	•	•	•	•	•	•	•	•	•	•
65507 6" Designer Outside Corner Post	•	•	•	•	•	•	•	•	•	•	•	•	•	•	•	•	•	•	•	•	•	•	•	•	•	•	•	•	•	•	•	•	•	•	•	•	•
65520 Inside Corner Post	•	•	•	•	•	•	•	•	•	•	•	•	•	•	•	•	•	•	•	•	•	•	•	•	•	•	•	•	•	•	•	•	•	•	•	•	•
65521 Inside Corner Post – Dark Colours																	•	•	•	•	•	•	•	•	•	•	•	•	•	•	•	•	•	•	•	•	•
65560 1/2" J-Channel	•	•	•	•	•	•	•	•	•	•	•	•	•	•	•	•	•	•	•	•	•	•	•	•	•	•	•	•	•	•	•	•	•	•	•	•	•
65536 5/8" Premium J-Channel	•	•	•	•	•	•	•	•	•	•	•	•	•	•	•	•	•	•	•	•	•	•	•	•	•	•	•	•	•	•	•	•	•	•	•	•	•
65533 3/4" Premium J-Channel	•	•	•	•	•	•	•	•	•	•	•	•	•	•	•	•	•	•	•	•	•	•	•	•	•	•	•	•	•	•	•	•	•	•	•	•	•
65540 1-1/8" J-Channel	•	•	•	•	•	•	•	•	•	•	•	•	•	•	•	•	•	•	•	•	•	•	•	•	•	•	•	•	•	•	•	•	•	•	•	•	•
65606 1-1/4" J-Channel	•	•	•	•	•	•	•	•	•	•	•	•	•	•	•	•	•	•	•	•	•	•	•	•	•	•	•	•	•	•	•	•	•	•	•	•	•
65538 2-1/2" Wide Face J-Channel	•	•	•	•	•	•	•	•	•	•	•	•	•	•	•	•	•	•	•	•	•	•	•	•	•	•	•	•	•	•	•	•	•	•	•	•	•
65570 Undersill Trim	•	•	•	•	•	•	•	•	•	•	•	•	•	•	•	•	•	•	•	•	•	•	•	•	•	•	•	•	•	•	•	•	•	•	•	•	•
65571 Undersill Trim – Dark Colours																	•	•	•	•	•	•	•	•	•	•	•	•	•	•	•	•	•	•	•	•	•
67750 Double Undersill Trim	•	•	•	•	•	•	•	•	•	•	•	•	•	•	•	•	•	•	•	•	•	•	•	•	•	•	•	•	•	•	•	•	•	•	•	•	•
65581 Drip Cap	•	•	•	•	•	•	•	•	•	•	•	•	•	•	•	•	•	•	•	•	•	•	•	•	•	•	•	•	•	•	•	•	•	•	•	•	•
65590 Beltline Trim	•	•	•	•	•	•	•	•	•	•	•	•	•	•	•	•	•	•	•	•	•	•	•	•	•	•	•	•	•	•	•	•	•	•	•	•	•
65700 Surround Starter	•																																				
65551 Starter Strip																																					•
65599 F-Channel	•	•	•	•	•	•	•	•	•	•	•	•	•	•	•	•	•	•	•	•	•	•	•	•	•	•	•	•	•	•	•	•	•	•	•	•	•
68080 3/4" F-Channel	•																																				
65568 3/8" Soffit Cove J-Channel	•																																				
65548 Soffit Double Channel	•																																				
65579 Soffit Cove Moulding	•																																				
65578 Soffit Crown Moulding	•																																				
65516 Variegated 3-1/2" OCP																																					•
65566 Variegated 1/2" J-Channel																																					•
65532 Variegated 3/4" J-Channel																																					•
65575 Variegated Undersill Trim																																					•
65559 Variegated Drip Cap																																					•
65595 Variegated Beltline											•																										•
68030 Bay & Bow Outside Corner Post	•																																				•
68020 Beaded Corner Post w/Insulation	•																																				•
65583 3-1/2" Window/Door Surround	•	•						•						•																							•
65750 5" Window/Door Surround	•																																				•
68035 3-1/2" H-Trim	•																																				•

# ALUMINUM AND STEEL SIDING, AND ALUMINUM SOFFIT AND FASCIA COLOUR MATRIX

• Available in this colour.

Colour Palette	Deluxe Aluminum				Woodgrain 2000			
	8" Horizontal	Double 4" Clapboard	8" Vertical Board & Batten	Vertical "V"	8" Horizontal	Double 4" Clapboard	Double 4" Dutch Lap	8" Vertical Board & Batten
431 Bright White	•	•	•	•	•	•	•	•
429 Ice White								
432 Almond	•	•	•	•	•	•	•	•
425 Black				•				•
467 Burgundy	•	•	•	•	•	•	•	•
410 Canyon Clay	•	•	•	•	•	•	•	•
414 Cashmere	•	•	•	•	•	•	•	•
454 Chestnut Brown	•	•	•	•	•	•	•	•
462 Commercial Brown	•	•	•	•	•	•	•	•
457 Dark Drift	•	•	•	•	•	•	•	•
436 Dover Gray	•	•	•	•	•	•	•	•
456 Forest Green	•	•	•	•	•	•	•	•
402 Maize	•	•	•	•	•	•	•	•
459 Pebble	•	•	•	•	•	•	•	•
447 Sable	•	•	•	•	•	•	•	•
408 Sandalwood	•	•	•	•	•	•	•	•
440 Sandstone	•	•	•	•	•	•	•	•
423 Slate	•	•	•	•	•	•	•	•
407 Tan	•	•	•	•	•	•	•	•
438 Wicker	•	•	•	•	•	•	•	•

Gentek offers a wider range of colours in Aluminum but with higher minimum quantities. Please check with your local Gentek distributor for enhanced colour line up and minimum order quantities.

	Colour Palette												
<b>Sierra Steel with Kynar PVDF</b>	431 Bright White	796 Chelsea Bluff	795 Delray Sand	836 Dover Gray	4P6 Iron Ore	633 Juniper Grove	673 Monterey Sand	637 Rockwell Blue	712 Sable	470 Storm	793 Taylor Red	826 Thistle	714 Watermill Blue
Double 4" Clapboard	•	•	•	•	•	•	•	•	•	•	•	•	•
Double 5" Clapboard	•	•	•	•	•	•	•	•	•	•	•	•	•
8" Horizontal	•	•	•	•	•	•	•	•	•	•	•	•	•
12" Vertical Board & Batten	•	•	•	•	•	•	•	•	•	•	•	•	•

Colour Palette	Aluminum Soffit					Aluminum Fascia									
	16" 2-Panel Standard Gauge	16" 2-Panel Heavy Gauge	16" 4-Panel Standard Gauge	16" 4-Panel Heavy Gauge	18" 3-Panel Heavy Gauge	4" Standard Gauge, Ribbed	4" Economy Gauge, Ribbed	6" Standard Gauge, Ribbed	6" Economy Gauge, Ribbed	6" Heavy Gauge, Ribbed	6" Heavy Gauge, Plain	8" Standard Gauge, Ribbed	8" Heavy Gauge, Ribbed	8" Heavy Gauge, Plain	10" Standard Gauge, Ribbed
431 Bright White	•	•				•	•	•	•	•	•	•	•	•	•
429 Ice White	•	•													
430 Rainware White			•	•											
432 Almond	•	•	•	•	•	•	•	•	•	•	•	•	•	•	•
475 AluCopper	•	•	•	•	•	•	•	•	•	•	•	•	•	•	•
165 Antique Brown	•	•	•	•	•	•	•	•	•	•	•	•	•	•	•
425 Black	•	•	•	•	•	•	•	•	•	•	•	•	•	•	•
322 Bright Red	•	•	•	•	•	•	•	•	•	•	•	•	•	•	•
471 Brownstone	•	•	•	•	•	•	•	•	•	•	•	•	•	•	•
467 Burgundy	•	•	•	•	•	•	•	•	•	•	•	•	•	•	•
410 Canyon Clay	•	•	•	•	•	•	•	•	•	•	•	•	•	•	•
414 Cashmere	•	•	•	•	•	•	•	•	•	•	•	•	•	•	•
5C1 Chesapeake Gray	•	•	•	•	•	•	•	•	•	•	•	•	•	•	•
454 Chestnut Brown	•	•	•	•	•	•	•	•	•	•	•	•	•	•	•
462 Commercial Brown	•	•	•	•	•	•	•	•	•	•	•	•	•	•	•
436 Dover Gray	•	•	•	•	•	•	•	•	•	•	•	•	•	•	•
456 Forest Green	•	•	•	•	•	•	•	•	•	•	•	•	•	•	•
5P5 Graphite	•	•	•	•	•	•	•	•	•	•	•	•	•	•	•
422 Ivy Green	•	•	•	•	•	•	•	•	•	•	•	•	•	•	•
402 Maize	•	•	•	•	•	•	•	•	•	•	•	•	•	•	•
5P4 Metallic Gray	•	•	•	•	•	•	•	•	•	•	•	•	•	•	•
5P8 Monterey Sand	•	•	•	•	•	•	•	•	•	•	•	•	•	•	•
468 Nutmeg	•	•	•	•	•	•	•	•	•	•	•	•	•	•	•
442 Old World Blue	•	•	•	•	•	•	•	•	•	•	•	•	•	•	•
459 Pebble	•	•	•	•	•	•	•	•	•	•	•	•	•	•	•
447 Sable	•	•	•	•	•	•	•	•	•	•	•	•	•	•	•
417 Sage	•	•	•	•	•	•	•	•	•	•	•	•	•	•	•
408 Sandalwood	•	•	•	•	•	•	•	•	•	•	•	•	•	•	•
440 Sandstone	•	•	•	•	•	•	•	•	•	•	•	•	•	•	•
423 Slate	•	•	•	•	•	•	•	•	•	•	•	•	•	•	•
470 Storm	•	•	•	•	•	•	•	•	•	•	•	•	•	•	•
407 Tan	•	•	•	•	•	•	•	•	•	•	•	•	•	•	•
435 Wedgewood Blue	•	•	•	•	•	•	•	•	•	•	•	•	•	•	•
438 Wicker	•	•	•	•	•	•	•	•	•	•	•	•	•	•	•
5P9 Coastal Blue	•	•	•	•	•	•	•	•	•	•	•	•	•	•	•
457 Dark Drift	•	•	•	•	•	•	•	•	•	•	•	•	•	•	•
5P3 Espresso	•	•	•	•	•	•	•	•	•	•	•	•	•	•	•
5C2 Hudson Slate	•	•	•	•	•	•	•	•	•	•	•	•	•	•	•
4P6 Iron Ore	•	•	•	•	•	•	•	•	•	•	•	•	•	•	•
5C5 Majestic Brick	•	•	•	•	•	•	•	•	•	•	•	•	•	•	•
5C6 Marine Dusk	•	•	•	•	•	•	•	•	•	•	•	•	•	•	•
5C3 Meadow Fern	•	•	•	•	•	•	•	•	•	•	•	•	•	•	•
409 Midnight Surf	•	•	•	•	•	•	•	•	•	•	•	•	•	•	•
413 Moonlit Moss	•	•	•	•	•	•	•	•	•	•	•	•	•	•	•
5C4 Rockport Brown	•	•	•	•	•	•	•	•	•	•	•	•	•	•	•
5P2 Rockwell Blue	•	•	•	•	•	•	•	•	•	•	•	•	•	•	•
5C7 Smoked Timber	•	•	•	•	•	•	•	•	•	•	•	•	•	•	•
406 Windswept Smoke	•	•	•	•	•	•	•	•	•	•	•	•	•	•	•

# ALUMINUM TRIM, FLAT STOCK, GUTTER COIL AND STEEL ACCESSORIES COLOUR MATRIX

• Available in this colour.

	Colour Palette																																					
	431 Bright White	429 Ice White	430 Rainware White	432 Almond	475 AluCopper	265 Antique Brown	425 Black	322 Bright Red	471 Brownstone	567 Burgundy	410 Canyon Clay	414 Cashmere	5C1 Chesapeake Gray	454 Chestnut Brown	462 Commercial Brown	436 Dover Gray	456 Forest Green	5P5 Graphite	422 Ivy Green	501 Lambeth Beige	402 Maize	5P4 Metallic Gray	5P8 Monterey Sand	468 Nutmeg	442 Old World Blue	459 Pebble	447 Sable	417 Sage	408 Sandalwood	440 Sandstone	423 Slate	470 Storm	407 Tan	435 Wedgewood Blue	438 Wicker			
2550 Snap-Lock Sill Trim	•			•	•	•	•	•	•	•	•	•	•	•	•	•	•	•	•	•	•	•	•	•	•	•	•	•	•	•	•	•	•	•	•	•		
0109025 Universal Starter Strip				•	•	•	•	•	•	•	•	•	•	•	•	•	•	•	•	•	•	•	•	•	•	•	•	•	•	•	•	•	•	•	•	•		
2502 3/4" J-Trim	•	•	•	•	•	•	•	•	•	•	•	•	•	•	•	•	•	•	•	•	•	•	•	•	•	•	•	•	•	•	•	•	•	•	•	•		
2312 Outside Corner Post (Woodgrain)	•	•	•	•	•	•	•	•	•	•	•	•	•	•	•	•	•	•	•	•	•	•	•	•	•	•	•	•	•	•	•	•	•	•	•	•		
2319 Outside Corner Post (Smooth)	•	•	•	•	•	•	•	•	•	•	•	•	•	•	•	•	•	•	•	•	•	•	•	•	•	•	•	•	•	•	•	•	•	•	•	•		
2503 Universal J	•	•	•	•	•	•	•	•	•	•	•	•	•	•	•	•	•	•	•	•	•	•	•	•	•	•	•	•	•	•	•	•	•	•	•	•		
2538 L-Trim Small	•	•	•	•	•	•	•	•	•	•	•	•	•	•	•	•	•	•	•	•	•	•	•	•	•	•	•	•	•	•	•	•	•	•	•	•		
2543 Drip Cap	•	•	•	•	•	•	•	•	•	•	•	•	•	•	•	•	•	•	•	•	•	•	•	•	•	•	•	•	•	•	•	•	•	•	•	•		
2504 Undersill Trim	•	•	•	•	•	•	•	•	•	•	•	•	•	•	•	•	•	•	•	•	•	•	•	•	•	•	•	•	•	•	•	•	•	•	•	•		
2567 Roof Edge Drip Cap	•	•	•	•	•	•	•	•	•	•	•	•	•	•	•	•	•	•	•	•	•	•	•	•	•	•	•	•	•	•	•	•	•	•	•	•		
2573 Roof Edge 3" 0 Degree 9'10"	•			•	•	•	•	•	•	•	•	•	•	•	•	•	•	•	•	•	•	•	•	•	•	•	•	•	•	•	•	•	•	•	•	•		
2575 Roof Edge 4" 0 Degree 9'10"	•			•	•	•	•	•	•	•	•	•	•	•	•	•	•	•	•	•	•	•	•	•	•	•	•	•	•	•	•	•	•	•	•	•		
2577 Roof Edge 6" 0 Degree 9'10"	•			•	•	•	•	•	•	•	•	•	•	•	•	•	•	•	•	•	•	•	•	•	•	•	•	•	•	•	•	•	•	•	•	•		
2043 Woodgrain Fascia Trim (BSP)	•	•	•	•	•	•	•	•	•	•	•	•	•	•	•	•	•	•	•	•	•	•	•	•	•	•	•	•	•	•	•	•	•	•	•	•		
2300 Individual Corner Cap	•			•	•	•	•	•	•	•	•	•	•	•	•	•	•	•	•	•	•	•	•	•	•	•	•	•	•	•	•	•	•	•	•	•		
2311 Individual Corner Cap Woodgrain	•			•	•	•	•	•	•	•	•	•	•	•	•	•	•	•	•	•	•	•	•	•	•	•	•	•	•	•	•	•	•	•	•	•		
2520 Soffit J (BSP)	•	•	•	•	•	•	•	•	•	•	•	•	•	•	•	•	•	•	•	•	•	•	•	•	•	•	•	•	•	•	•	•	•	•	•	•		
2507 3/4" Wideface Soffit J	•			•	•	•	•	•	•	•	•	•	•	•	•	•	•	•	•	•	•	•	•	•	•	•	•	•	•	•	•	•	•	•	•	•		
2522 Soffit J (OSP)				•	•	•	•	•	•	•	•	•	•	•	•	•	•	•	•	•	•	•	•	•	•	•	•	•	•	•	•	•	•	•	•	•		
1692 Channel Runner	•	•	•	•	•	•	•	•	•	•	•	•	•	•	•	•	•	•	•	•	•	•	•	•	•	•	•	•	•	•	•	•	•	•	•	•		
1690 Channel Runner				•	•	•	•	•	•	•	•	•	•	•	•	•	•	•	•	•	•	•	•	•	•	•	•	•	•	•	•	•	•	•	•	•		
<b>Aluminum Flat Stock</b>																																						
3036 24" x 50" (BSP) Heavy Gauge	•			•	•	•	•	•	•	•	•	•	•	•	•	•	•	•	•	•	•	•	•	•	•	•	•	•	•	•	•	•	•	•	•	•		
3037 24" x 98-1/2" (BSP)	•	•	•	•	•	•	•	•	•	•	•	•	•	•	•	•	•	•	•	•	•	•	•	•	•	•	•	•	•	•	•	•	•	•	•	•	•	
3039 24" x 98-1/2" (OSP)	•			•	•	•	•	•	•	•	•	•	•	•	•	•	•	•	•	•	•	•	•	•	•	•	•	•	•	•	•	•	•	•	•	•	•	
3304 24" x 50" (BSP)	•			•	•	•	•	•	•	•	•	•	•	•	•	•	•	•	•	•	•	•	•	•	•	•	•	•	•	•	•	•	•	•	•	•	•	
3531 24" x 98-1/2" (BSP)	•			•	•	•	•	•	•	•	•	•	•	•	•	•	•	•	•	•	•	•	•	•	•	•	•	•	•	•	•	•	•	•	•	•	•	
3311 PVC Striated 24" x 50" (OSP)				•	•	•	•	•	•	•	•	•	•	•	•	•	•	•	•	•	•	•	•	•	•	•	•	•	•	•	•	•	•	•	•	•	•	
<b>Aluminum Gutter Coil</b>																																						
3025 Downpipe Coil 10-1/2" (OSP)		•	•	•	•	•	•	•	•	•	•	•	•	•	•	•	•	•	•	•	•	•	•	•	•	•	•	•	•	•	•	•	•	•	•	•	•	
3006 Gutter Coil 11-7/8" (OSP)				•	•	•	•	•	•	•	•	•	•	•	•	•	•	•	•	•	•	•	•	•	•	•	•	•	•	•	•	•	•	•	•	•	•	•
3009 Gutter Coil 11-7/8" (BSP)	•			•	•	•	•	•	•	•	•	•	•	•	•	•	•	•	•	•	•	•	•	•	•	•	•	•	•	•	•	•	•	•	•	•	•	•
3045 Gutter Coil 11-7/8" (OSP) Heavy Gauge			•	•	•	•	•	•	•	•	•	•	•	•	•	•	•	•	•	•	•	•	•	•	•	•	•	•	•	•	•	•	•	•	•	•	•	•
3049 Gutter Coil 11-7/8" (BSP) Heavy Gauge				•	•	•	•	•	•	•	•	•	•	•	•	•	•	•	•	•	•	•	•	•	•	•	•	•	•	•	•	•	•	•	•	•	•	•
3012 Gutter Coil 13-1/2" (BSP)				•	•	•	•	•	•	•	•	•	•	•	•	•	•	•	•	•	•	•	•	•	•	•	•	•	•	•	•	•	•	•	•	•	•	•
3084 Gutter Coil 6" (BSP)				•	•	•	•	•	•	•	•	•	•	•	•	•	•	•	•	•	•	•	•	•	•	•	•	•	•	•	•	•	•	•	•	•	•	•

Designer Colours												
5P9 Coastal Blue	•	•	•	•	•	•	•	•	•	•	•	•
557 Dark Drift	•	•	•	•	•	•	•	•	•	•	•	•
5P3 Espresso	•	•	•	•	•	•	•	•	•	•	•	•
5C2 Hudson Slate	•	•	•	•	•	•	•	•	•	•	•	•
4P6 Iron Ore	•	•	•	•	•	•	•	•	•	•	•	•
5C5 Majestic Brick	•	•	•	•	•	•	•	•	•	•	•	•
5C6 Marine Dusk	•	•	•	•	•	•	•	•	•	•	•	•
5C3 Meadow Fern	•	•	•	•	•	•	•	•	•	•	•	•
509 Midnight Surf	•	•	•	•	•	•	•	•	•	•	•	•
513 Moonlit Moss	•	•	•	•	•	•	•	•	•	•	•	•
5C4 Rockport Brown	•	•	•	•	•	•	•	•	•	•	•	•
5P2 Rockwell Blue	•	•	•	•	•	•	•	•	•	•	•	•
5C7 Smoked Timber	•	•	•	•	•	•	•	•	•	•	•	•
506 Windswept Smoke	•	•	•	•	•	•	•	•	•	•	•	•
Neutral	•	•	•	•	•	•	•	•	•	•	•	•

BSP-Both sides painted  
OSP-One side painted

Colour Palette												
431 Bright White	•	•	•	•	•	•	•	•	•	•	•	•
796 Chelsea Bluff	•	•	•	•	•	•	•	•	•	•	•	•
795 Delray Sand	•	•	•	•	•	•	•	•	•	•	•	•
836 Dover Gray	•	•	•	•	•	•	•	•	•	•	•	•
4P6 Iron Ore	•	•	•	•	•	•	•	•	•	•	•	•
633 Juniper Grove	•	•	•	•	•	•	•	•	•	•	•	•
673 Monterey Sand	•	•	•	•	•	•	•	•	•	•	•	•
637 Rockwell Blue	•	•	•	•	•	•	•	•	•	•	•	•
712 Sable	•	•	•	•	•	•	•	•	•	•	•	•
470 Storm	•	•	•	•	•	•	•	•	•	•	•	•
793 Taylor Red	•	•	•	•	•	•	•	•	•	•	•	•
826 Thistle	•	•	•	•	•	•	•	•	•	•	•	•
714 Watermill Blue	•	•	•	•	•	•	•	•	•	•	•	•

Steel Accessories												
1835 3/4" Outside Corner Post – Kynar	•	•	•	•	•	•	•	•	•	•	•	•
1842 3/4" J-Channel – Kynar	•	•	•	•	•	•	•	•	•	•	•	•
1841 1-1/8" J-Channel – Kynar	•	•	•	•	•	•	•	•	•	•	•	•
1850 Snap-Lock Finish – Kynar	•	•	•	•	•	•	•	•	•	•	•	•
1715 24" x 50" Alum. Trim Coil – Poly	•	•	•	•	•	•	•	•	•	•	•	•

Steel Flat Stock												
1877/29-GA 20-7/8" x 50'	•	•	•	•	•	•	•	•	•	•	•	•

# ARCHITECTURAL SPECIFICATIONS

## VINYL SIDING AND SOFFIT ARCHITECTURAL SPECIFICATIONS

Produced to precise tolerances using formulated compounds specifically designed for the plastic building products industry according to ASTM D4216, meeting or exceeding the following:

Property	ASTM Test	Results
Tensile Strength (psi)	D-638	6,700
Modulus of Elasticity (psi)	D-638	410,000
Izod Impact (70°F)	D-256	3.6 (ft-lb/in of notch)
Izod Impact (32°F)	D-256	2.0 (ft-lb/in of notch)
Flexural Strength (psi)	D-790	14,000
Coefficient of Linear Expansion	D-696	5.3 x 10 <sup>-5</sup> (mm/mm °C) 2.9 x 10 <sup>-5</sup> (in/in °F)
Deflection Temperature Under Load 264 psi (°C)	D-648	73

### PRODUCT PHYSICALS:

All siding products, soffit panels and accessories are made with solid colour throughout. The siding products and accessories meet or exceed the ASTM Specification for Rigid Poly Vinyl Chloride (PVC) Siding D3679. All soffit products and associated accessories meet or exceed the ASTM Specification for Rigid (Unplasticized) Poly Vinyl Chloride (PVC) Soffit D4477.

The siding and soffit compound meets Class 2 requirements and conforms to weathering performances as described in ASTM 3679.

Colour: Spectrophotometer controlled  
Gloss: Gardner gloss meter controlled  
Lock: Dimensionally controlled

All products meet or exceed ASTM 3679 thickness (nominal) requirements:

<i>Sequoia Select EnFusion</i>	0.046"
<i>Sequoia Select</i>	0.046"
<i>Sequoia Select Variegated</i> (except Board & Batten)	0.046"
<i>Northern Forest Elite</i>	0.046"
<i>Board &amp; Batten</i>	0.048"
<i>Fair Oaks</i>	0.044"
<i>Concord</i>	0.042"
<i>Driftwood II</i>	0.040"
<i>Sequoia Select Ultra-Premium Soffit</i>	0.044"
<i>Oxford Premium Soffit</i>	0.042"
<i>Beaded Premium Soffit</i>	0.042"
<i>Fairweather Soffit</i>	0.040"

### WARRANTY:

All Gentek vinyl siding brands carry a Lifetime Limited Warranty including fade and hail protection. *Warranty is transferable if the home is sold. See printed warranty for complete details.*

### SOFFIT VENTILATION AREA:

Gentek soffit panels are designed to allow air circulation into the attic areas to aid in the reduction of excessive heat buildup and water vapor condensation. The net free open area (NFOA) per lineal foot of soffit is as follows:

12" <i>Sequoia Select Hidden Vented</i>	10 sq in
10" <i>Oxford Fully Vented</i>	5.3 sq in
8" <i>Beaded Vented</i>	2.4 sq in
12" <i>Fairweather Center Vented</i>	2.3 sq in
12" <i>Fairweather Fully Vented</i>	7.1 sq in

### FIRE RESISTANCE RATINGS:

Gentek vinyl siding products meet or exceed all building code requirements throughout the United States and Canada. In addition to meeting these code requirements, Gentek vinyl sidings have been fire rated by Underwriters Laboratories (UL) to be used in one-hour rated designed walls U026 and U032 and a two-hour rated wall, U301. UL inspects the manufacture of the vinyl products quarterly to certify that Gentek vinyl products are manufactured consistently. The vinyl products have been tested as follows:

Property	ASTM Test	Results
<i>Average Burn Distance</i>	D-635	20mm
<i>Average Burn Time</i>	D-635	<5 seconds
<i>Flash Ignition Temperature</i>	D-1929	752°F
<i>Self Ignition Temperature</i>	D-1929	860°F
<i>Flame Spread Index</i>	E-84	15
<i>Smoke Developed Index</i>	E-84	<400
<i>Fire Resistance</i>	E-119	1-hour rated* 2-hour rated*

\*See UL Fire Resistance Directory Control No. 1N60. E-119 is equivalent to UL-263 and E-84 is equivalent to UL-723.

### Important fire safety information for the building trades, specifiers, professionals and do-it-yourself installers:

When rigid vinyl siding is exposed to significant heat or flame, the vinyl will soften, sag, melt, or burn and may thereby expose the material underneath. Care must be exercised when selecting underlay materials because many underlays are made from organics that are combustible. You should ascertain the fire properties of any underlay prior to installation. All building materials should be installed in accordance with local, state and federal building codes and fire regulations.

### WINDLOAD PROPERTIES:

All Gentek siding products are designed to withstand a minimum of 100 mph windloads and are suitable for most areas. The products can be used in areas with higher windloads, but installation procedures, choice of product and building code jurisdiction are important factors to be considered. The windspeed rating (in mph) is calculated using VSI's windspeed calculation guidelines. Additional information is available if required.

### BUILDING CODES:

Gentek vinyl products meet or exceed the following building code specifications:

ICC-ESR – 1133  
CCMC – 06541-L  
New York City MEA 132-94-M  
FHA/HUD Minimum Property Standards

**For architectural specifications of designer siding and other products, please see your local Gentek dealer.**

# ARCHITECTURAL SPECIFICATIONS

## ALUMINUM SIDING ARCHITECTURAL SPECIFICATIONS

### ALUMINUM METAL PROPERTIES:

Alloy or equivalent .....	AA3000
Specific Gravity .....	2.72
Modulus of Elasticity (ksi) .....	10,000
Melting Range (°F) .....	1175-1210

**COATING PROPERTIES:** Gentek aluminum products are manufactured with AA3000 series alloy (or equivalent). Both sides of the aluminum are cleaned with a specially formulated cleaner. The cleaned aluminum is then treated with an acid solution containing chrome to enhance corrosion resistance and coating adhesion.

**Plastisol (Poly) Topcoat:** The topside of the pretreated aluminum is coated with a thermoset polyester polymer which is dried and cured at about 450 °F., forming a hard but flexible and weatherable coating. Total coating thickness is approximately 18 micrometers.

**Plastisol (PVC) Topcoat:** This highly weatherable, flexible, chemical-resistant thermoplastic polymer is melted and fused on the aluminum metal at temperatures of 390°F. The coating is applied either with a striated pattern or smooth finish having an average film thickness of 3.0 mils.

**Fluoropolymer (PVDF):** This thermoplastic polymer has excellent chemical and fade resistance. The coating is applied at 0.9 mil. The system is cured at a minimum temperature of 475°F. This polymer system conforms to the high industry standards of Kynar 500® and Hylar 5000®. The main criteria for these standards is that the paint formulation must contain a minimum of 70% PVDF2. Many fluoropolymer coatings on the market do not meet the high quality and performance standards required by Kynar 500 and Hylar 5000 specifications.

**WEATHERING AND TESTING:** Gentek products are tested for superior adhesion and forming properties. Gentek's stringent colour specifications allow batch to batch mixing of product. Product testing includes colour, film thickness, gloss, hot water/impact test, freezer/impact test, salt spray, humidity testing (1000 hours) and outdoor exposure (2 years).

**COMPLIANCE:** All Gentek soffits comply with CAN/CGSB-93.2-M91. In addition, the aluminum alloys used meet the ULC Standard CAN4-S114-M80, defining the noncombustibility of aluminum alloys.

**WARRANTY:** 40 Year Limited Warranty. Warranty is transferable.

### CONTACT WITH DISSIMILAR MATERIALS AND CORROSIVE ENVIRONMENTS:

Direct contact of aluminum products with certain dissimilar materials, or contact with water runoff from dissimilar materials, is likely to result in corrosion. Accordingly, care should be taken during installation to avoid such contact of aluminum with dissimilar materials, including: dissimilar metals (copper, zinc, steel, etc.), concrete, stucco, asbestos siding, pressure treated/pretreated lumber, masonry, corrosive non-metallic materials, and roofing materials or roofing systems containing metallic granules or strips. Seacoast or other corrosive environments may result in corrosion of the product.

### NOMINAL GAUGES (mm):

Product	Gauge
8" Horizontal.....	0.53
D4 Dutch Lap.....	0.40
D4 Clapboard .....	0.40 & 0.44
8" Vertical Board & Batten .....	0.50
Vertical "V" .....	0.40
16" Soffit – 2 Panel.....	0.29 & 0.38
16" Soffit – 4 Panel.....	0.29 & 0.38
18" Soffit – 3 Panel.....	0.33
4" Fascia – rib .....	0.44
6" Fascia – rib & non-rib.....	0.44 & 0.50
8" Fascia – rib & non-rib.....	0.44 & 0.50
Gutter Coil.....	0.57, 0.66 & 0.79

### SOFFIT VENTILATION AREA:

Gentek soffit is available in a variety of profiles. Vented panels are designed to allow air circulation into the attic areas to aid in the reduction of excessive heat build-up and water vapour condensation. Gentek soffit conforms to CCMC 12860-L.

PROFILE	PER LINEAR FOOT	PER PANEL
16" – 2 panel	4.02 sq in (26.0 cm <sup>2</sup> )	48.8 sq in (314 cm <sup>2</sup> )
16" – 4 panel	4.12 sq in (26.6 cm <sup>2</sup> )	66.6 sq in (429.7 cm <sup>2</sup> )
18" – 3 panel	5.46 sq in (32.2 cm <sup>2</sup> )	78.5 sq in (506.5 cm <sup>2</sup> )

**VENTILATION:** Fully vented

## STEEL SIDING ARCHITECTURAL SPECIFICATIONS

### METAL PROPERTIES:

<i>Steel or Equivalent</i>	AZ-50
<i>Specific Gravity</i>	7.8
<i>Minimum Ultimate Strength (KSI)</i>	45-55
<i>Minimum Yield (KSI)</i>	40-50
<i>Minimum Elongation (%)</i>	25-35
<i>Modulus of Elasticity (KSI)</i>	29,500
<i>Coefficient of Thermal Expansion (in/in °F)</i>	0.000006
<i>Melting Range (°F) Steel</i>	>2700
<i>Melting Range (°F) Zinc</i>	786
<i>Thermal Conductivity at 77°F (btu-in/ft<sup>2</sup>-hr-°F)</i>	555

### COATING PROPERTIES:

Gentek steel siding products are manufactured with AZ-50. Both sides of the steel sheet are cleaned with a specially formulated cleaner, water rinsed and then coated with an environmentally safe chemical pretreatment to enhance corrosion protection and coating adhesion.

The pretreated surface is coated with a thermoset corrosion-resistant polymer. This corrosion-resistant polymer is topcoated with the following polymeric systems:

**Plastisol (PVC) Topcoat:** This highly weatherable, flexible, chemical-resistant thermoplastic polymer is melted and fused at temperatures of >390°F. The coating is applied with a striated pattern or smooth finish having an average film thickness of 3.0 mils.

**Fluoropolymer (PVDF):** This thermoplastic polymer has excellent chemical and fade resistance. The coating thickness is 0.9 mil. The system is cured at a minimum temperature of 475°F. This polymer system conforms to the high industry standards of Kynar 500® and Hylar 5000®. The main criteria for these standards is that the paint formulation must contain a minimum of 70% PVDF2. Many fluoropolymer coatings on the market do not meet the high quality and performance standards required by Kynar 500 and Hylar 5000 specifications.

### WARRANTY:

All Gentek steel siding brands carry a Lifetime Limited Warranty. *Warranty is transferable if home is sold. See printed warranty for complete details.*

### CONTACT WITH DISSIMILAR MATERIALS:

Direct contact of steel products with certain dissimilar materials, or contact with water runoff from dissimilar materials, is likely to result in corrosion. Accordingly, care should be taken during installation to avoid such contact of steel with dissimilar materials, including: dissimilar metals (copper, zinc, steel, etc.), concrete, stucco, asbestos siding, pressure treated/pretreated lumber, masonry, corrosive non-metallic materials, and roofing materials or roofing systems containing metallic granules or strips.

### PRODUCT PHYSICALS:

Product	Coating Type	Thickness*
Sierra Steel	PVDF <sub>2</sub>	0.017
SteelSide	PVC	0.017
Universal	PVC	0.017

\*29 Gauge

### BUILDING CODES:

Gentek steel products meet or exceed the following building code specifications:

ICC-ES Legacy – Report #97-64  
AAMA 1406-86  
FHA/HUD Minimum Property Standards

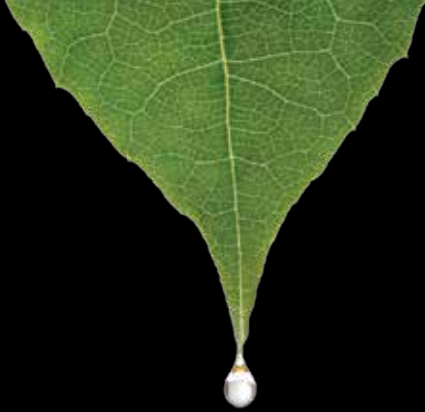

## BETTER PRODUCTS FOR A BRIGHTER FUTURE

You may not realize it, but building green begins long before the materials are ready for installation on a home. It begins with a firm commitment to “source reduction” by the manufacturer, ensuring all aspects of production are designed to help reduce the volume and environmental impact of waste, while also achieving optimum material use to create products with a longer service life.

- Eco-friendly and sustainable, Gentek vinyl siding and windows help conserve natural resources often used for home construction, such as cedar and other wood. And because vinyl never needs to be painted, it helps prevent paint, stain and other maintenance-related materials from entering the waste stream.
- All Gentek aluminum siding is produced from material that is at least 90% recycled aluminum. At the end of its long useful life, aluminum siding is 100% recyclable.
- Unlike some building materials, such as fiber cement, steel siding is a recyclable material and has long been North America’s most recycled material!<sup>1</sup> It also promotes energy conservation by creating a tight building envelope for more efficient heating/cooling performance year-round.

## SERVICE AND SELECTION ABOVE ALL

At Gentek, we appreciate the often-challenging schedule of the building products professional. That’s why we do our very best to stock our supply centres with everything you need to get the job done efficiently and with beautiful results. Our knowledgeable and friendly staff is readily available to fill your orders, process special requests, offer solutions and assist with whatever you need.

## VALUABLE WARRANTY PROTECTION

Gentek delivers the confidence and value only a true leader can provide. We proudly stand behind our products with the full faith of our more than 50 years of manufacturing expertise and some of the strongest warranties in the industry.

For complete warranty information, including limitations, ask your dealer for a copy of the Gentek-brand product warranties. Warranty information for specialty sidings and third-party products can be found on their respective websites.



1001 Corporate Drive | Burlington, ON L7L 5V5  
gentek.ca | *Make us a part of your home.*



<sup>1</sup>Steel: The Clear Cut Alternative for Building Homes. Steel Recycling Institute, [www.recycle-steel.org](http://www.recycle-steel.org). \*Windload performance may vary by profile design. Product improvement policy: Gentek Building Products is constantly improving product designs and manufacturing processes. We therefore must reserve the right to change specifications without notice. Colours may not be exactly as shown due to lithographic process. Please consult Gentek Building Products for current details. Trademarks mentioned in this document are the property of Gentek Building Products, its affiliates, or their respective owners. Accessible formats and communication supports available upon request.