



**Introducing the EnergyPlus™ Quattro Glass Package from Gentek®
New Dual-Glazed System is Designed to meet Latest ENERGY STAR® Performance Requirements**

Burlington, Ontario – Gentek®, a leading manufacturer of exterior building products, announces the launch of the EnergyPlus™ Quattro Glass Package. Meeting the latest ENERGY STAR® performance requirements brought forth in 2000, this ultra-efficient glass package achieves triple-glazed glass performance that can save as much as 25 to 30 percent of residential heating and cooling energy use*.

Available on Gentek's line of [Regency®](#), [Regency® 400 Series](#) and [80 Series all-environment vinyl windows](#), this high efficiency, dual-glazed system features:

- Two surfaces of Low-E technology that helps to reflect heat back into the home interior, significantly increasing the Energy Rating (ER) value
- High Performance Low-E glass; and
- Super Spacer® Non-Metal Space System, which creates an insulating air space between the panes of glass that serve as a thermal barrier.

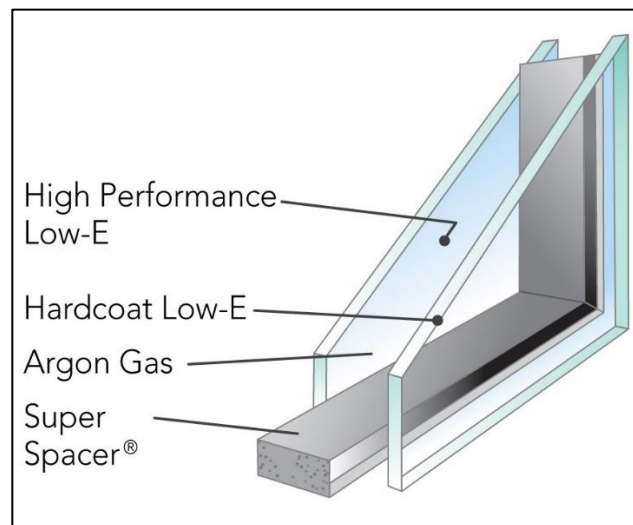

“With ENERGY STAR as the mark of high-efficiency products in Canada, we’re extremely proud the EnergyPlus Quattro Glass Package has earned this certification and meets the strict technical specifications,” said Philippe Bourbonniere, executive vice president, Gentek Building Products. “The ultra-efficient design of our energy-engineered Regency, Regency 400 Series and 80 Series vinyl windows are expertly crafted to maximize the energy efficiency of your home and reduce energy costs.”

Gentek’s window lines encompass all the hallmarks of exceptional window design—superior quality and energy efficiency, along with functional beauty and maintenance freedom, and are endorsed by a lifetime limited warranty. For more information on Gentek Building Products, visit gentek.ca

**www.energy.gov/energysaver/design/windows-doors-and-s Skylights/update-or-replace-windows*

###

About Gentek

Gentek’s mission is to create successful partnerships with contractors, builders, distributors, and dealers by providing and servicing industry leading exterior building products and solutions. The company helps partners create or restore exceptional residential, multi-family, and light commercial structures that are energy-efficient, comfortable, long-lasting, and beautiful for the home or building owner. Gentek operates more than 20 company-owned supply centers across Canada and is owned by Associated Materials, LLC. For more information, or to locate your local Gentek supply centre, visit gentek.ca.