



LONGBOARD®
INSPIRING ARCHITECTURE

Link & Lock™ Cladding

Installation Guidelines

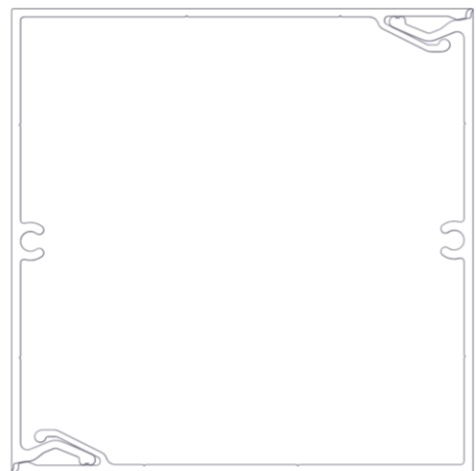
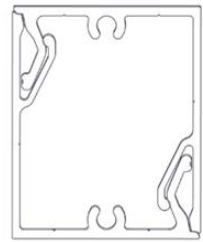
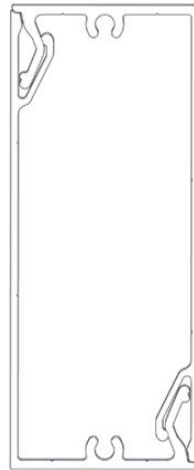
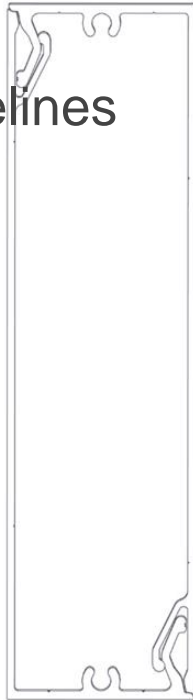

Table of Contents

Material Specifications	3
Finishes	3
Expansion and contraction	3
Material ordering and deliveries	3
Storage and handling	3
Cleaning	3
Warranty	3
Graffiti Removal	4
Components	5
Components (Typical)	5
Tools/Cutting/Fastening	6
Tools	6
Cutting	6
Fastening	7
Fastener types	7
Framing requirements	8
System Install	9
Install details	9
Typical dimensions	9
System layout and Install steps	10
Perimeter and field area limitations	10
Preparation drilling for Install	11
Butt-Joints & Lap Joints	12
Batten orientation	13-14
Fin orientation	15
End to End orientation	16-17
Large spans with Stiffener	18-20
Link & Lock HD	21
4x4 & 4x6 Link & Lock	22
Link & Lock Brackets	23-27
Appendix	28
Tables - Expansion & contraction	28
Tables - Allowable Attachment Span	29-32
Handling and care of products	33
Contact Info	34

Material Specifications

Finishes

- Longboard Products are available in a wide range of powder coated finishes
- Custom solid colors are available upon request

Longboard extruded products are produced 1" (25mm) oversized, as one end is drilled for the coating process and both ends have 1/2" (12mm) of masking tape (woodgrains only) which must be cut off for best results.

Expansion & Contraction

Link & Lock components expand & contract 1/4" (6mm) over 24' (7.3m) along the length, measured over a 30°C (54°F) temperature range. Due to this range of movement, Link & Lock Fins/Louvers/Battens should be installed with staggered butt-joints, leaving a 1/4" (6mm) min. gap, every 24' (7.3m) min. Alternatively, staggered lap-joints are an option for a continuous appearance, however 1/4" (6mm) gaps should be left at each joint to allow for thermal movement. Be sure to lap joints by 2' (610mm) minimum over the back "L". See **Appendix for Tables 1 & 2, expansion/contraction calculations per foot/meter of material.**

Material Ordering & Delivery

- | | |
|--------------|---|
| • Packaging: | Link & Lock is sold by the set (pair) and in widths of 2", 4", 6", 8"
End caps are sold by the box: 20 caps/bx
End Mounts are sold by the box: 20 mounts/bx
Stiffener is sold in 24' lengths (includes Double-sided Tape) |
| • Shipping: | Most Popular Finishes -ready to ship within 1 week
Additional Finishes -ready to ship within 14 weeks
Delivered on 24' (7.3m) long skids weighing up to 2000 lbs. A mechanical lift with forks is required on site to receive the order. |
| • QC: | Always inspect the delivery for damage and contact LB ASAP if there are any issues: info@longboardproducts.com or 1-800-604-0343 and include your PO# and any pictures if possible. Mark the delivery receipt as "damaged" and accept the delivery as-is. Longboard is not responsible for the installation of blemished or damaged material. |

Storage & Handling

Be sure to store the material flat, keep it dry, safe & secure and remain in unopened cartons until ready to be installed. See **Appendix for proper handling and care instructions.**

Cleaning Recommendations

- Initial and periodic cleaning for best looking product
- Basic methods use a combination of moderate water pressure, soft sponge/brush and a mild detergent (Safe for your hands, safe for the product)

⚠ NEVER use aggressive acid or alkaline cleaners on Longboard finishes. Do not use cleaners containing Trisodium Phosphate, Phosphoric Acid, Hydrochloric Acid, Hydrofluoric Acid, Fluorides, or any other compound that is known to react with metal.

***See Cleaning Guide for full requirements & cleaning schedule:**
longboardproducts/resources/care-maintenance.com

Warranty

Upon substantial completion of the project, register for warranty online here: longboardproducts.com/warranty

⚠ Registration is required for the warranty to be in effect.

Graffiti Removal

Standard Woodgrain
 Use Standard soap & water only

D2000 Solid Color

	Prosoco Cleaner	MEK Solvent
Permanent Marker	<input checked="" type="checkbox"/>	<input checked="" type="checkbox"/>
Oil Based Spray Paint	<input checked="" type="checkbox"/>	<input checked="" type="checkbox"/>
Water Based Spray Paint	<input checked="" type="checkbox"/>	<input checked="" type="checkbox"/>
Adhesive Tape	<input checked="" type="checkbox"/>	<input checked="" type="checkbox"/>

MEK Solvent

Prosoco Anti-Graffiti Cleaner

SPECIAL ORDER - EXT. LEAD TIMES CONTACT LB

Anti-Graffiti High Gloss Woodgrain

	MEK Solvent
Permanent Marker	<input checked="" type="checkbox"/>
Oil Based Spray Paint	<input checked="" type="checkbox"/>
Water Based Spray Paint	<input checked="" type="checkbox"/>
Adhesive Tape	<input checked="" type="checkbox"/>

MEK Solvent

Note: Cleaning the surface with a cleanser that is not diluted as per instructions may result in damage to the coating.

Components

Components (Typical)

The Link & Lock™ system consists of two (2) matching L-shaped extrusions, snapped together to make a complete set. For all LB components go to longboardproducts.com.

Link & Lock™ Battens

Size	12'	24'	End Caps (20/box)	End Mounts (20/box)
2"	2X2LL.145	2X2LL.289	2LLEC.2	2LLEM.2
4"	2X4LL.145	2X4LL.289	2LLEC.4	2LLEM.4
6"	2X6LL.145	2X6LL.289	2LLEC.6	2LLEM.6
8"	2X8LL.145	2X8LL.289	2LLEC.8	2LLEM.8

Link & Lock™ HD Battens

6"	2X6LLHD.145	2X6LLHD.289	2LLHDEC.6	2LLHDEM.6
8"	2X8LLHD.145	2X8LLHD.289	2LLHDEC.8	2LLHDEM.8

Link & Lock™ Box Battens

4 x 4"	4X4LL.145	4X4LL.289	4LLEC.4	-
4 x 6"	4X6LL.145	4X6LL.289	4LLEC.6	-



Mounting Accessories	Qty	SKU
Link & Lock Mounting Clip	48, bag	LLMC.N48
Dewalt® 1/2" Pilot Point Drill Bit	1	DRILLBT.05
24' Link & Lock Internal Stiffener	1	LLSTIFF.289
3M® Double Sided Adhesive Tape - 108'	1, roll	LLTAPE.1296

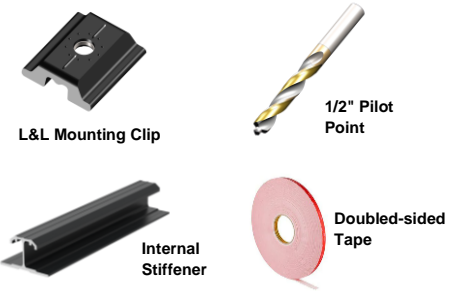

Link & Lock™ Mounting Brackets







Product	Single	Dual
45° LEFT FIXED	LLMBK.45LF	LLMDK.45LF
45° RIGHT FIXED	LLMBK.45RF	LLMDK.45RF
90° CENTER FIXED	LLMBK.90F	LLMDK.90F
45° LEFT SLIDING	LLMBK.45LS	LLMDK.45LS
45° RIGHT SLIDING	LLMBK.45RS	LLMDK.45RS
90° CENTER SLIDING	LLMBK.90S	LLMDK.90S

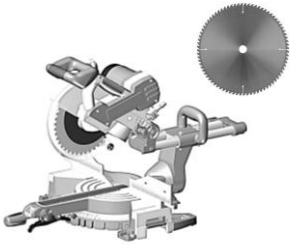

Tools/Cutting/Fastening

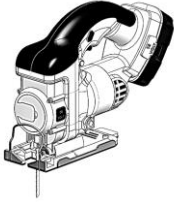
Tools

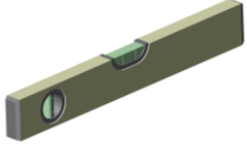
Commonly used tools for Link & Lock install.

			
Table Saw (Match blade type same as Miter Saw)	Miter Saw with Carbide Metal Blade Non-ferrous 60-80T (for cutting aluminum)	Cordless Drill with clutch	Jig Saw (for protrusions)
			
Rubber Mallet (or Hammer)	Level	Hole Saw (for lighting fixtures)	Quick Grip Bar Clamp

Cutting

⚠ Always be sure to wear appropriate PPE: eye & hearing protection.

Cut battens using a Miter Saw and Table Saw always allowing for expansion & contraction. Trim the taped/drilled ends of all stock length material by at least **1/2" (12mm) each end** and discard.

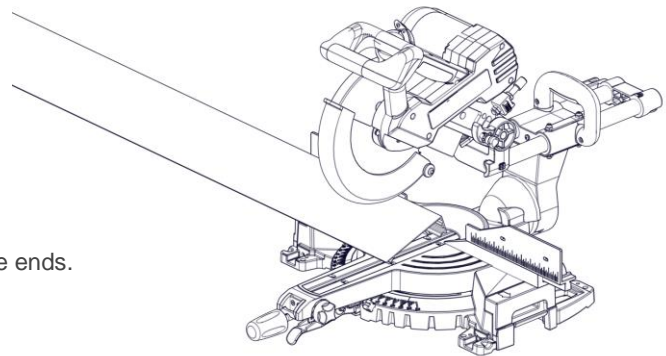

⚠ **DO NOT** Install Link & Lock without trimming the ends.

Fastening

Longboard Link & Lock™ consists of two (2) matching L-shaped extrusions, snapped together to make a complete set. The back “L” is mechanically fastened to the substrate, using Longboard **Mounting Clips** fastened every **6-8’ O.C. up to 12ft when using Stiffeners** with #12 (#14 for L&L HD) sharp-point screws (for wood substrates) or self-drilling (for metal substrates). The Mounting Clips are included in the order for 6’ spacings.

Fasteners must be corrosion resistant and comply with all local building codes.

⚠ All fasteners should be suitable for exterior use and be compatible with the substrate type. **Fasteners should be anchored into a solid secure substrate.**

Layout and predrill the back “L” at all fastener locations.
Refer to **Preparation drilling for Install** for hole dimensions and further details.

⚠ See **Appendix for project specific fastener spacing:**
Allowable Span - Tables 3-13

Fastener Types/Sizes for L&L		
L&L	Pan Head	Hex Head
2”	#12	#12
4”	#12	#12
6”	#12	#12
8”	#12	#12
4”x4”	#12	#12
4”x6”	#12	#12
6” HD	#14	#14
8” HD	#14	#14

Fastener types

RECOMMENDED

Pan-Head Rounded-Head Self-Drilling Flanged Hex Head



Mounting Clip

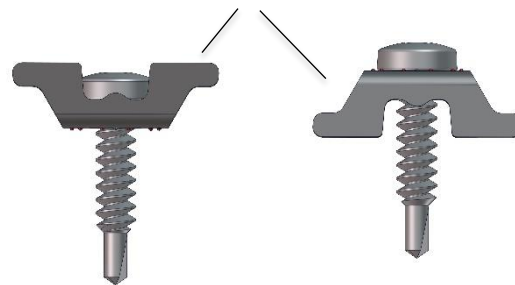

Batten (flat orientation)

Fin orientation

DO NOT USE

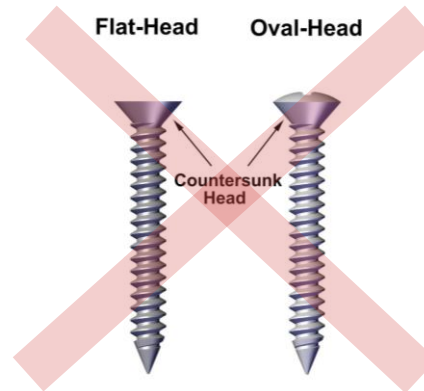

Fastener Types/Sizes for End Mounts		
End Mount	Pan Head	Hex Head
2"	#10	X
4"	#12	#12
6"	#12	#12
8"	#12	#12
6" HD	#14	#14
8" HD	#14	#14

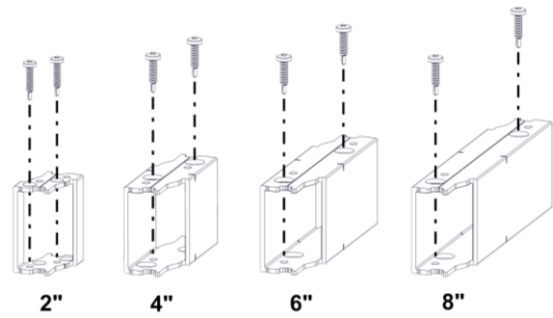

Framing requirements

Always consult your local building authority and follow local building code requirements. See Typical dimensions for sizes and weights of the L&L system.

Wood Framing

- Size: 2x4 minimum

Metal Framing

- Gauge: 18 ga. minimum

Concrete/CMU

Wood or metal furring is recommended over concrete and CMU.

Wood Furring:

- Size: 2x2 minimum
- Type: Pressure treated lumber

Metal Furring:

- Size: 18 ga. minimum
- Type: Hat channel, c-stud, or z-furring.

System Install

Install details

Typical dimensions

- Longboard Link & Lock system typical dimensions:

L&L	Width	Depth	Length	Weight(lbs/LF) *per set
2"	2" (50.8mm)	1 5/8" (41.3mm)	12'/24'	0.93
4"	4" (101.6mm)	1 5/8" (41.3mm)	12'/24'	1.3
6"	6" (152.4mm)	1 5/8" (41.3mm)	12'/24'	1.6
8"	8" (203mm)	1 5/8" (41.3mm)	12'/24'	1.9
4"x4"	4" (101.6mm)	4" (101.6mm)	12'/24'	1.8
4"x6"	6" (152.4mm)	4" (101.6mm)	12'/24'	2.1
6" HD	6" (152.4mm)	2" (50.8mm)	12'/24'	2.4
8" HD	8" (203mm)	2" (50.8mm)	12'/24'	3

- Longboard Products are not recommended for use on marine applications in direct contact with salt water.
- Link & Lock is an open-joint system which is required to be installed outboard of a weather resistant barrier, including all flashings, following code, and building requirements.
- It is good practice to leave a 1/4" (6mm) gap between every component joint or 24' (7.3m) to allow for expansion & contraction. Consider the joints where components meet each other to dictate which component is installed first (eg: right angle butt joints, mitered joints etc.).
- Mounting Clips allow for movement of the battens, to expand & contract during thermal changes.
- Fasten Mounting Clips every 6-8' typical (based on project wind load requirements), alternating from top to bottom for battens using die lines for guides.

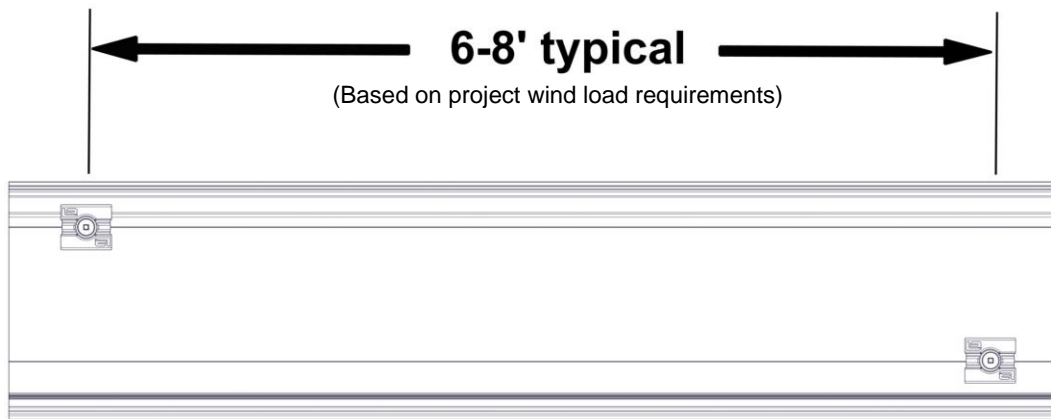

System layout and Install steps

Perimeter and field area limitations

Measure and layout your wall area to consider Link & Lock alignment with fixtures, penetrations, and adjacent walls, for desired appearance. The same methodology applies for vertical installations.

Seamless runs up to 24' length battens (no butt-joints)

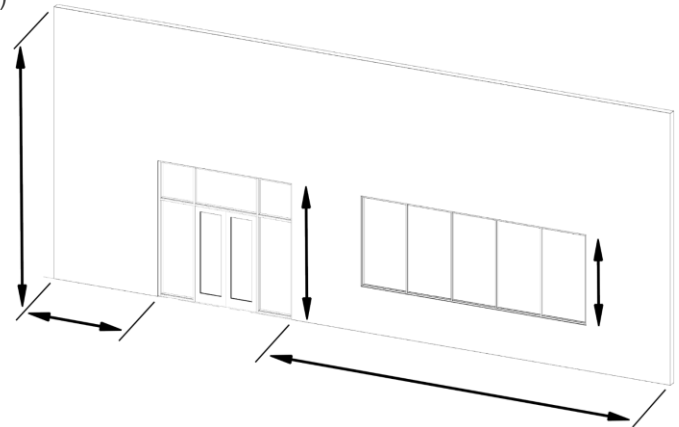
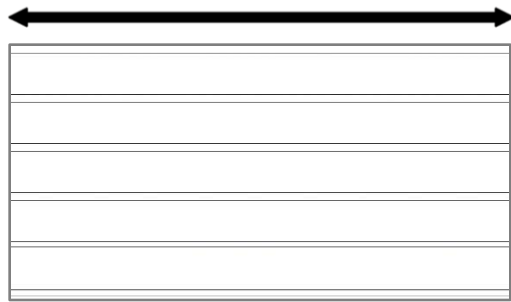

Runs with staggered butt-joints

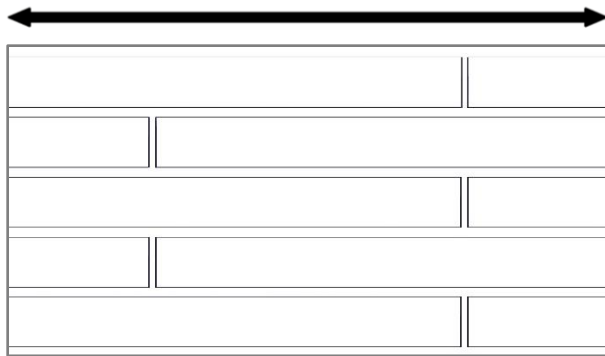

Runs with staggered lap-joints.

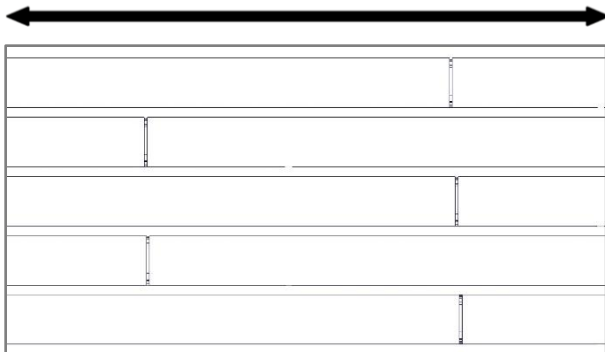

Preparation drilling for Install

To prepare Link & Lock for install, layout and predrill the back "L" with 1/2" holes every 6-8' O.C. typical, with the first hole 2" in from the end to allow space for the End Cap.

For the Batten orientation, alternate the holes from top to bottom using the Dielines for guides.

For Fin orientation, use Pilot Point Drill Bit (see below) as recommended for ease of drilling.

Note: To hard fasten 1 location per length, omit the drilled hole at that location and use for hard fastening.

See **Appendix for project specific fastener spacing:**

Allowable Span - Tables 3-13

⚠ Tip: Add weep holes as good practice to allow any potential moisture to escape.

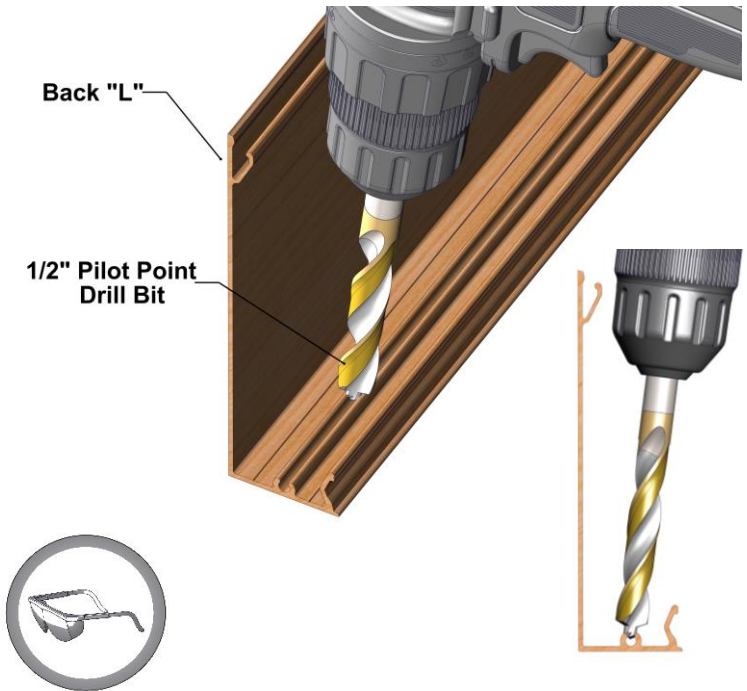
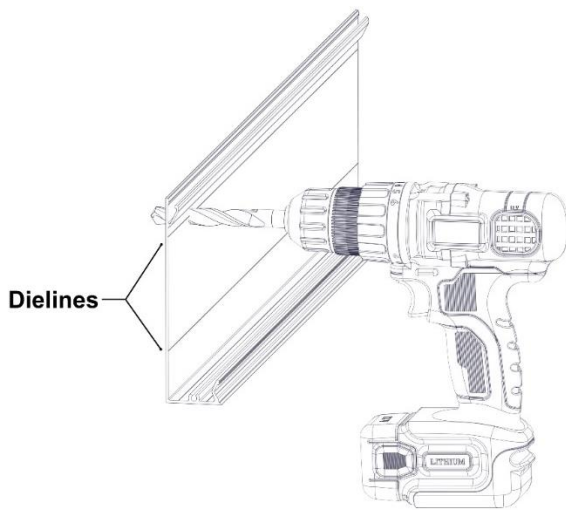
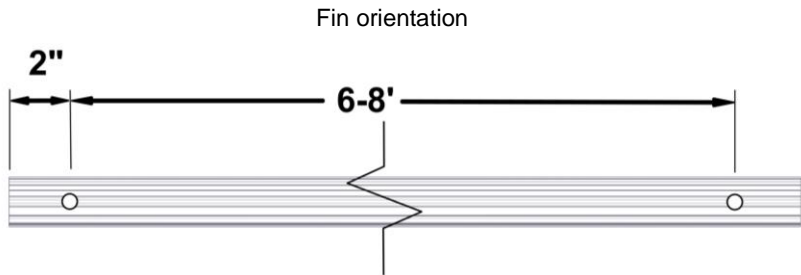
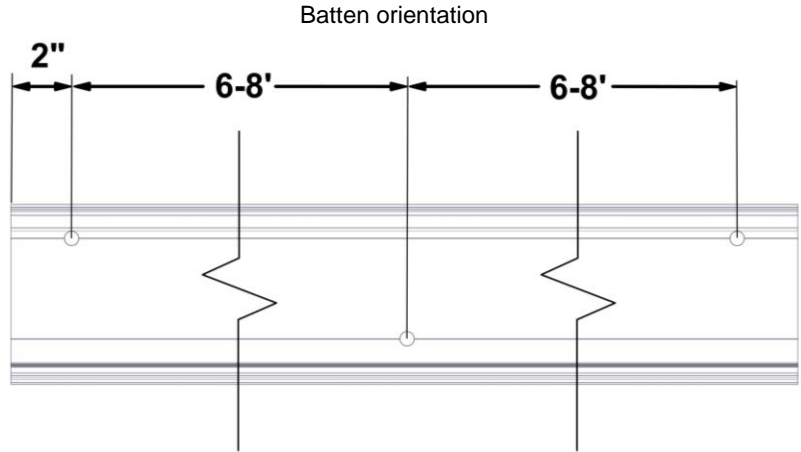

Butt-Joints & Lap Joints

- **⚠ BUTT-JOINTS.** When installing butt-joints, ensure to leave a 1/4" (6mm) min. gap. every 24' (7.3m) min. (See **Detail A**). Fasteners should be anchored into a solid secure framing member, blocking, furring strip, or backer plate, etc.
- **⚠ LAP-JOINTS.** When installing lap-joints, ensure to leave a 1/4" (6mm) min. gap. every 24' (7.3m) min. (See **Detail A**). Fasteners should be anchored into a solid secure framing member, blocking, furring strip, or backer plate, etc.
- If needed, use touch-up paint pens (purchased separately) to finish the ends at the butt-joint or lap-joint.
- It is good practice to hard-fasten each back "L" at one point per length typically near the center, to keep the battens from migrating.
- DO NOT hard-fasten more than one (1) location per batten.

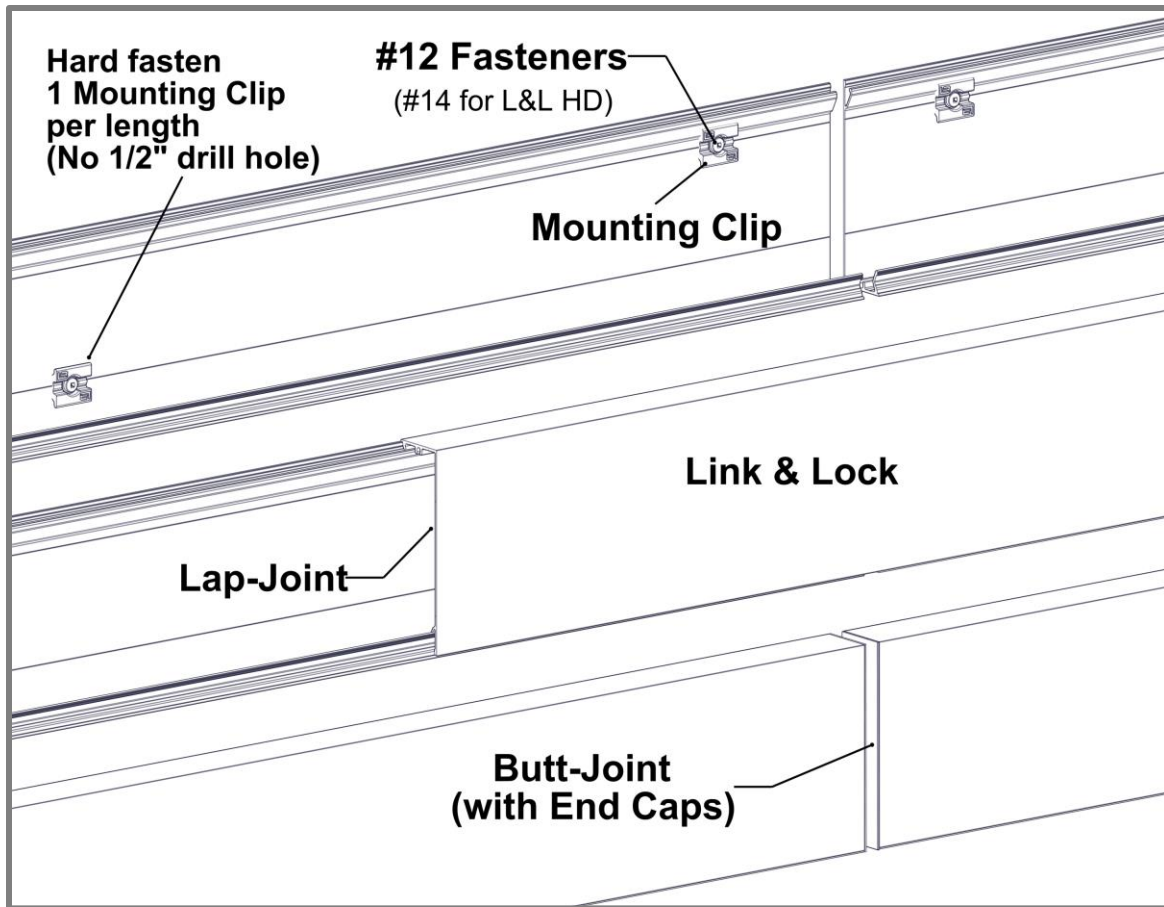

Detail A

Install Batten orientation

Step 1

Place predrilled Link & Lock back "L" into position (Drilling page 11). It is good practice to check your installation every 2-3 rows for level/plumb and flat/straight, for best results.

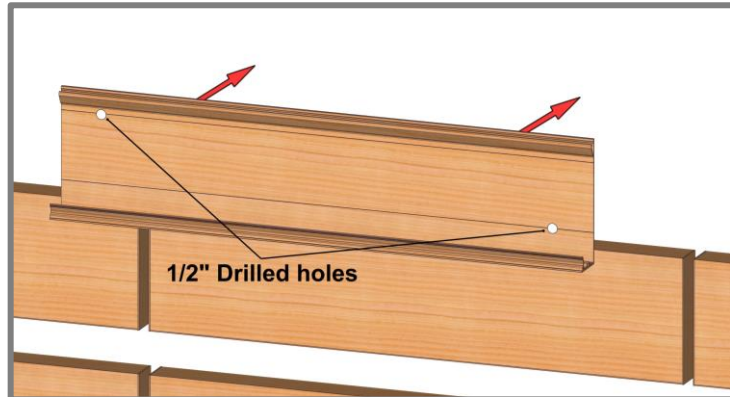

Step 2

Install back "L" using #12 Fasteners (#14 for L&L HD) and Mounting Clips every 6-8' O.C. typical.

Note: Be sure to fasten in the center of the 1/2" holes to allow for movement each way. Hard fasten near the center of each length to prevent migration of the material over time.

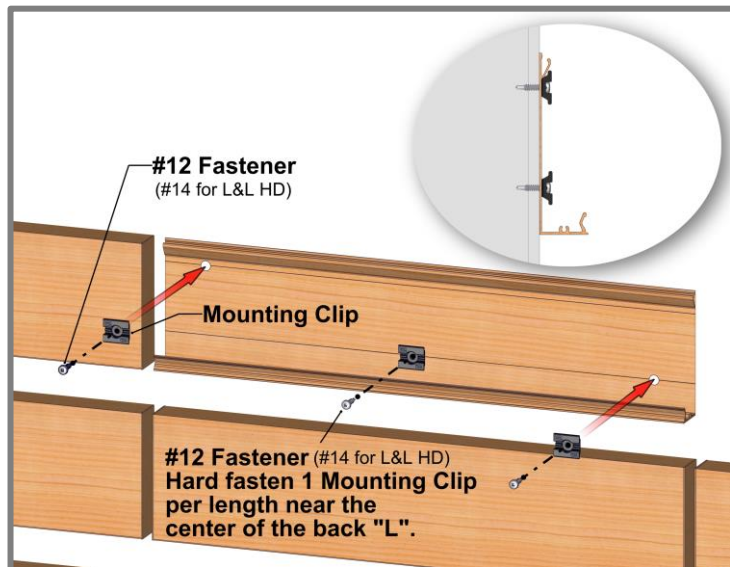

Step 3

Install front "L" and snap it into place, aligning it with ends and joints. If necessary, use a rubber mallet or hammer and block to protect the finish.

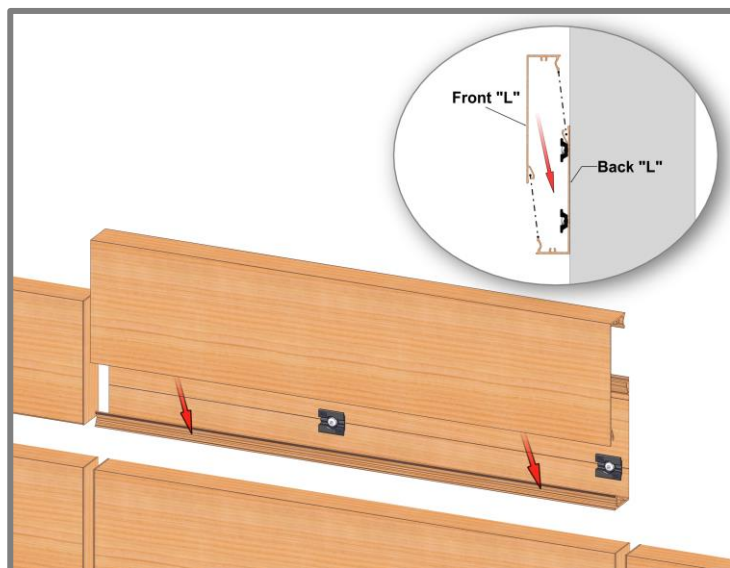

Step 3.1

Use clamps with rubber pads as common practice to securely snap the front "L" onto the back "L".

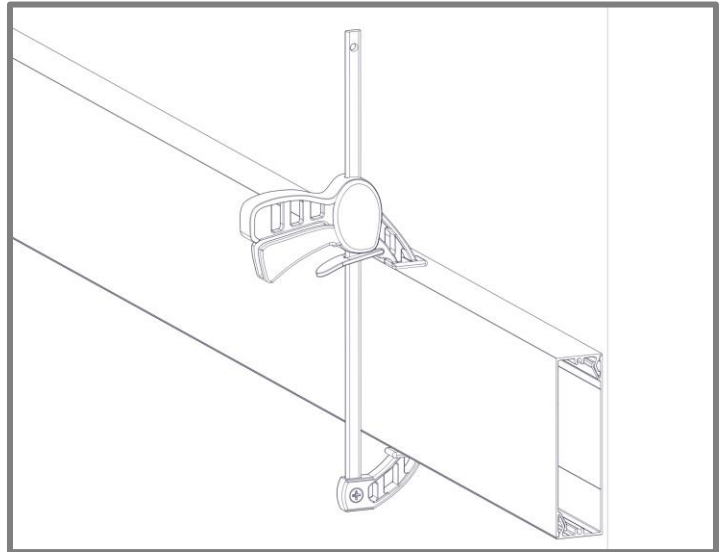

Step 4

Install End Caps, which are friction fit, by pressing them into place using the palm of your hand. If necessary, use a rubber mallet to snap them into place. See below images. Use paint pens to coat Link & Lock cut ends that may show slightly beyond the End Caps.

Consider your application sequence of the End Caps before installing adjacent Link & Lock members, as they may limit the space needed to insert the caps. In this situation you may need to install the caps first then the front "L" as seen in the image to the right.

▲ TIP: Use shim to hold/secure cap while snapping in the front "L".

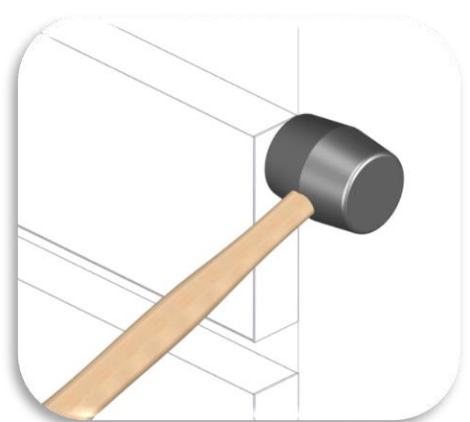
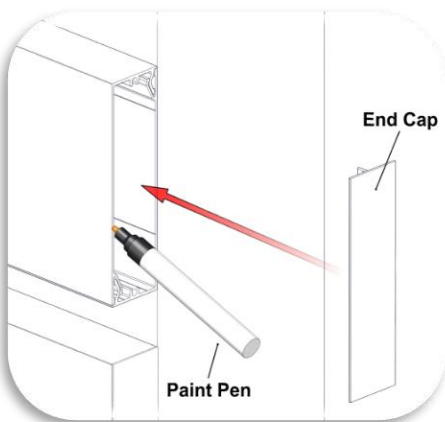
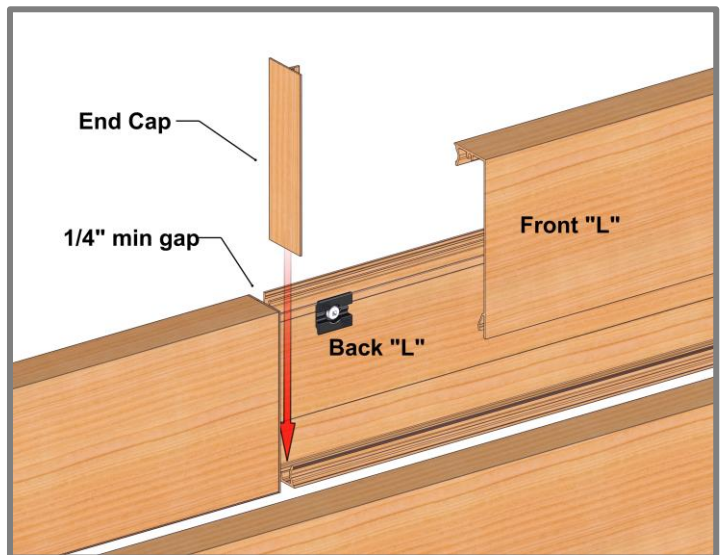

Install Fin orientation

Step 1

Place predrilled Link & Lock back “L” into position (Drilling page 11). It is good practice to check your installation every 2-3 rows for level/plumb and flat/straight, for best results.



Fin Orientation

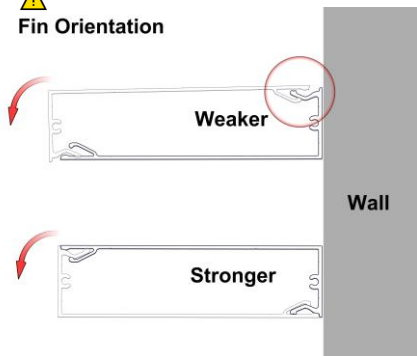

Step 2

Install back “L” using #12 Fasteners (#14 for L&L HD) and Mounting Clips every 6-8’ O.C. typical.

Note: Be sure to fasten in the center of the 1/2” holes to allow for movement each way. Hard fasten near the center of each length to prevent migration of the material over time.

Step 3

Install front “L” and snap it into place, aligning it with ends and joints. If necessary, use a rubber mallet or hammer and block to protect the finish.

Step 4

Refer to Page 14 for End Cap install and considerations.

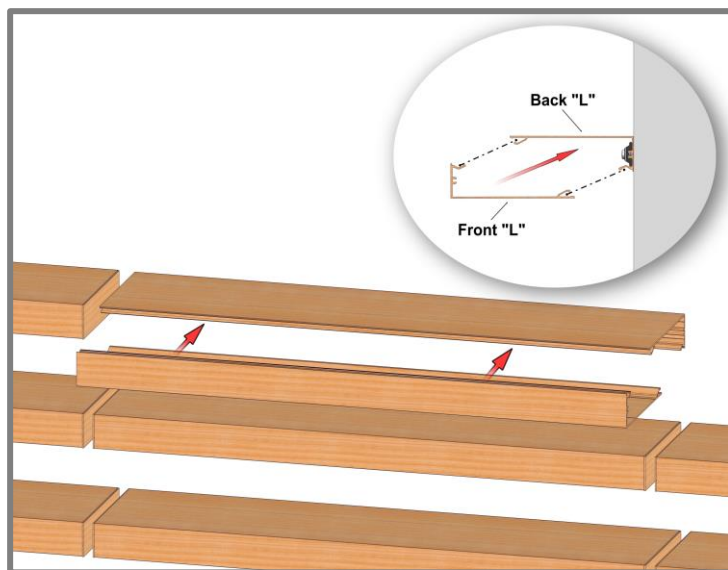
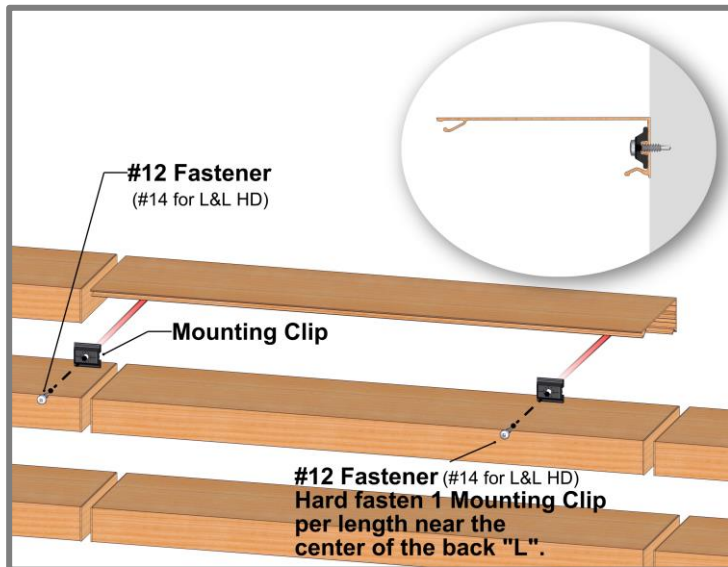
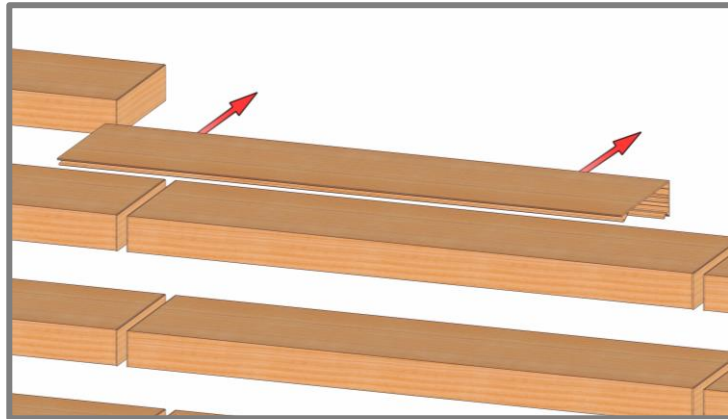

Install End to End orientation

Note: Use Tables 3-13 in Appendix for Allowable Span for Wind Loading.

Step 1

Place End Mounts into position at the top and bottom of the install. It is good practice to check your installation every 2-3 rows for level/plumb and flat/straight, for best results.

Fastener Types for End Mounts		
End Mount	Pan Head	Hex Head
2"	#10	
4"	#12	#12
6"	#12	#12
8"	#12	#12
6" HD	#14	#14
8" HD	#14	#14

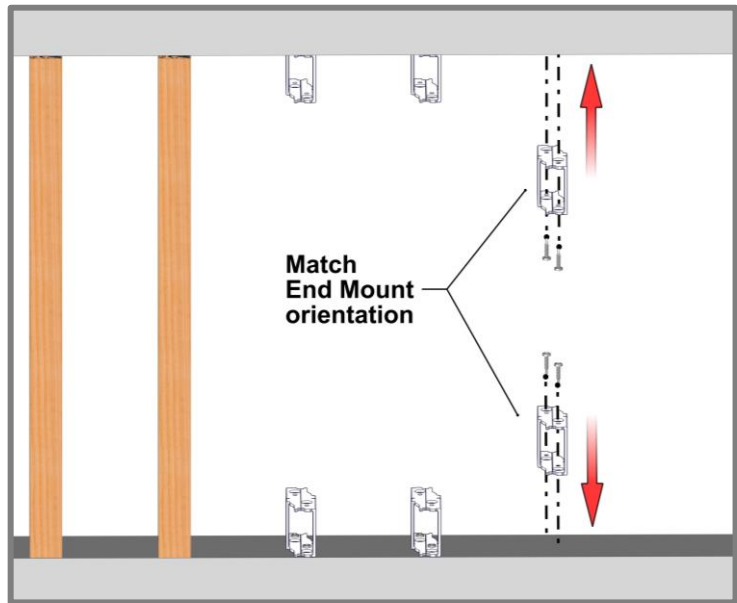

Step 2

Install the End Mounts using Fasteners (by others). Make sure to match the orientation of the End Mounts so the Link & Lock set matches on the top and the bottom. See above for **Fastener Types and sizing for End Mounts**.

▲ TIP: Check the position of the End Mounts once installed to allow a plumb and straight look.

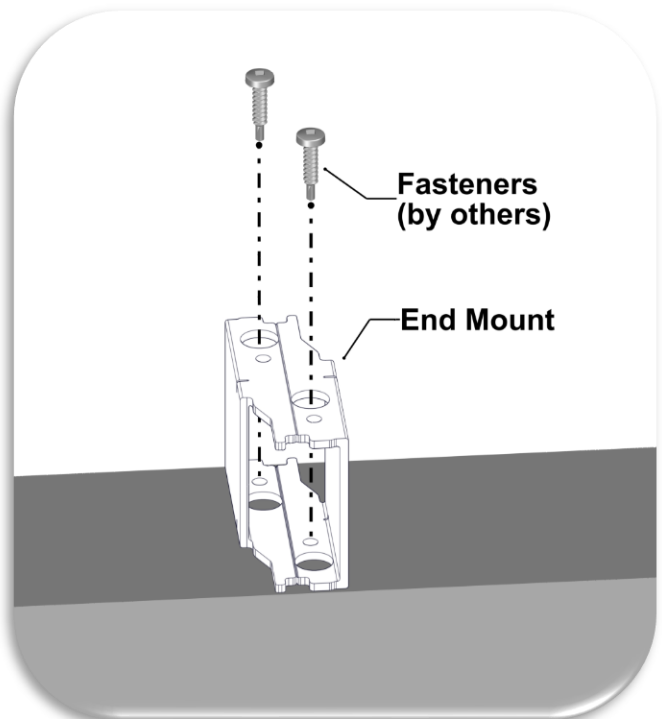
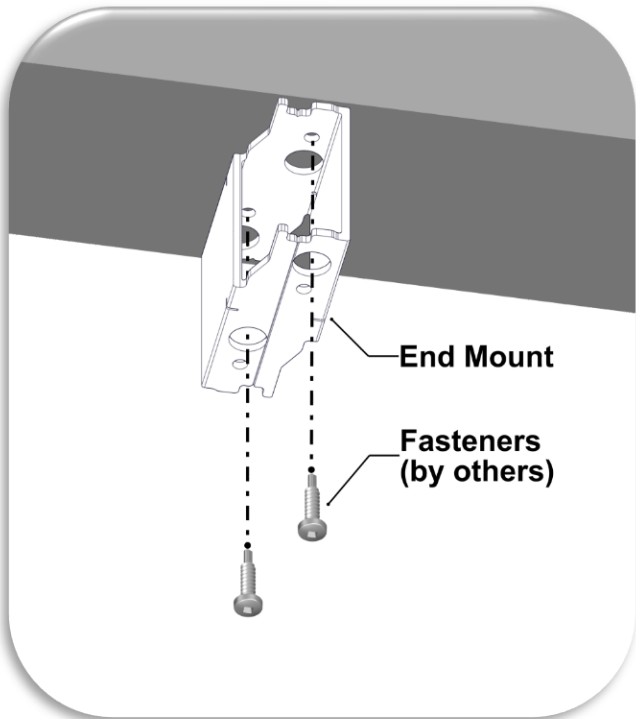

Step 3

Measure, cut and install Link & Lock Set and snap it into place onto the End Mounts. Use clamps with rubber pads as common practice to securely snap the front “L” onto the back “L”. If necessary, use a rubber mallet or hammer and block to protect the finish.

⚠ TIP: When measuring the Link & Lock, make sure to leave a gap (~1/4”) for expansion and building movement.

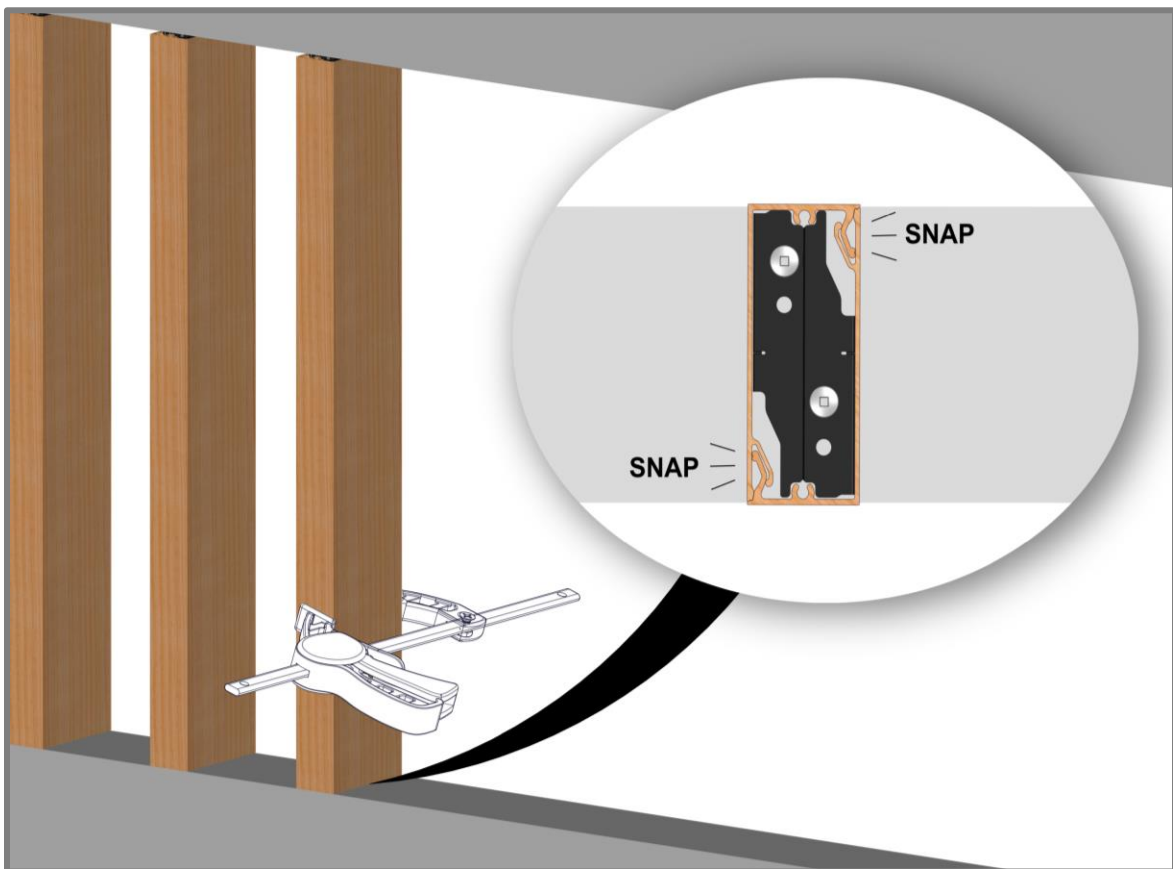
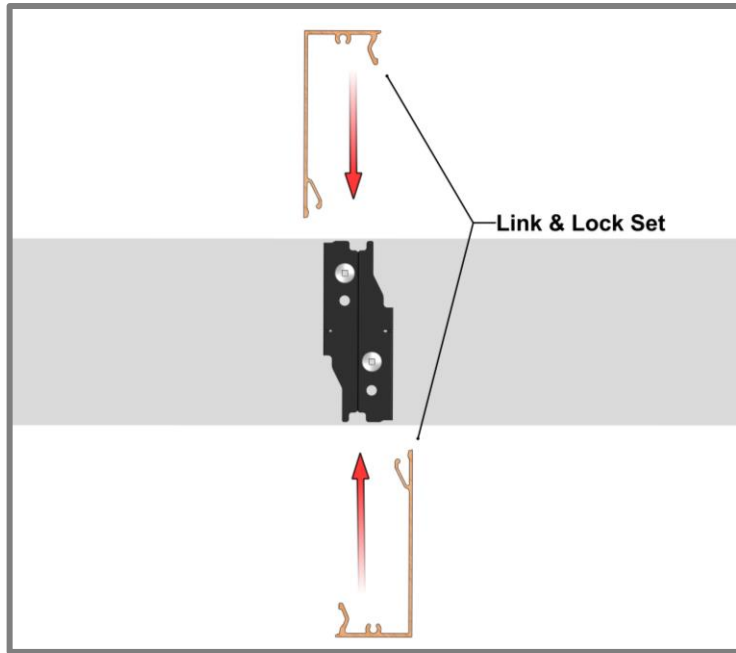
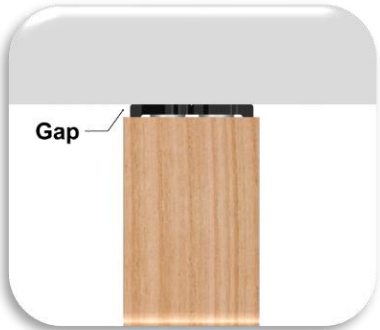

Large spans with Internal Stiffener

Requirements for large spans:

- Two Mounting Clips with #12 fasteners min, (#14 for L&L HD) are used at both ends with a minimum distance apart of 5" O.C.
- An Internal Stiffener is added to reinforce the Link & Lock set for spans up to 12' max @30psf.
- Stiffener must be one continuous member from attachment to attachment.
- Double-sided Tape is used to place the Stiffener onto the Link & Lock. The tape is placed on the center of the Stiffener and then pressed onto far end of the back "L" as shown on page 19.



See **Appendix for allowable spans for project specific wind load.**
Allowable Span - Tables 3-13

Step 1

Place predrilled Link & Lock back "L" into position (Drilling page 11). It is good practice to check your installation every 2-3 rows for level/plumb and flat/straight, for best results.

Step 2

Install back "L" using #12 Fasteners min, (#14 for L&L HD) and Mounting Clips at end attachment points with a minimum distance apart of 5" O.C.

Note: Be sure to fasten in the center of the 1/2" holes to allow for movement each way. Hard fasten one end of each length to prevent migration of the material over time.

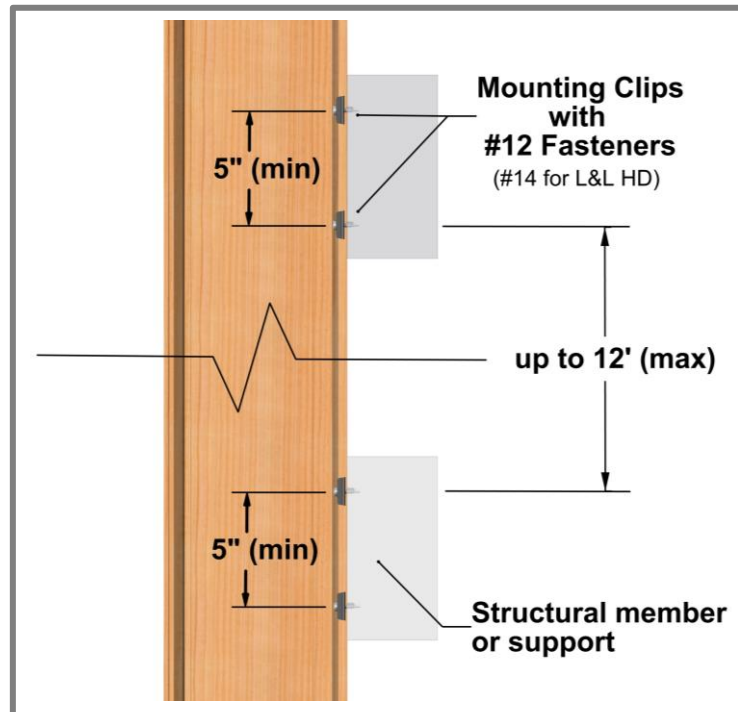

Step 3

Peel and place the Double-sided tape onto the back of the Stiffener O.C. Peel the second side and install the Stiffener as shown in the image pressing down to adhere to the tape.

Note: Install Stiffener 1" (min) from the end of the L&L to allow space for the End Cap as seen below.

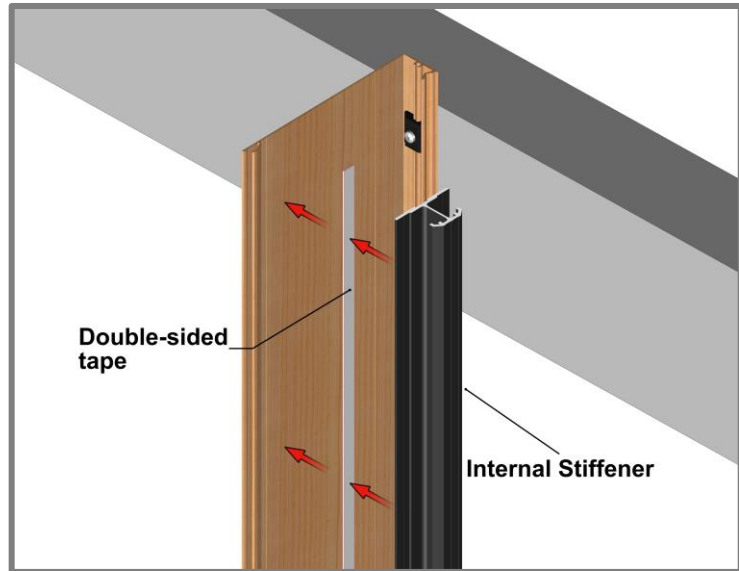

Make sure the Stiffener is located at the end of the back "L" and the tape is in the center of the stiffener.

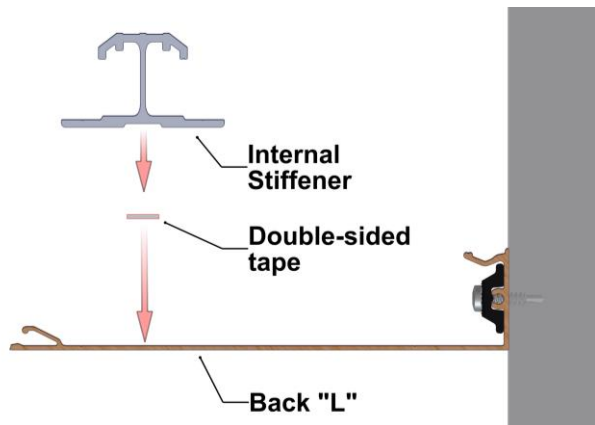

Step 4

-Fastening Stiffener in Fin orientation

Mechanically fasten the Stiffener to the back "L" using 1/8" Dome Head Rivets (Aluminum). Drill the flange of the Stiffener using a 1/8" Drill bit and fasten two Rivets at the top or one end to mitigate movement of the stiffener over time.

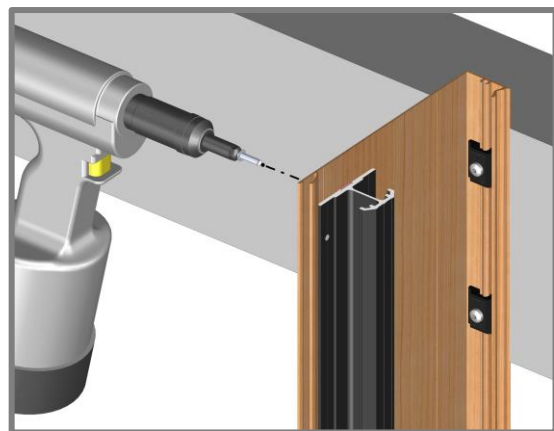

Step 4.1

-Fastening Stiffener Batten orientation
Mechanically fasten the Stiffener to the back "L" using the Mounting Clips and #12 Fasteners.

Refer to Step 2, Page 13 for mounting.

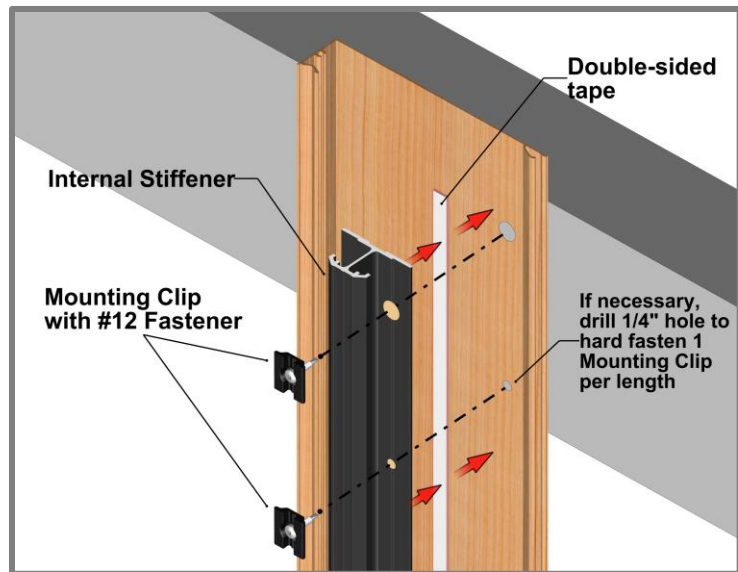

Step 5

Refer to Step 3 & 4 on Page 13-14 for Front "L" and End Cap install and details.



Link & Lock HD

- Used for greater spans compared to standard Link & Lock
- Available sizes: 6" & 8" (2" depth)
- Uses standard Mounting Clip and attachment methods
- Use #14 Fasteners

Refer to System Layout and Install steps section for typical install details.

To Compare allowable spans:
See **Appendix for allowable spans for project specific wind load.**
Allowable Span - Tables 3-11

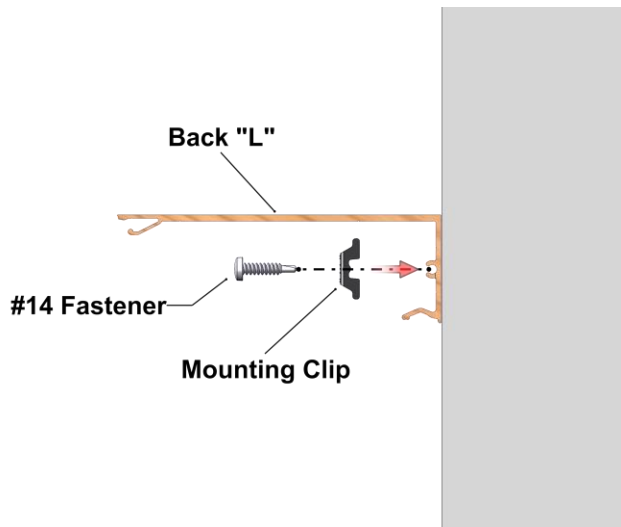

6" L&L
6' span max
@30PSF

6" L&L HD
12' span max
@30PSF

Profile Comparison

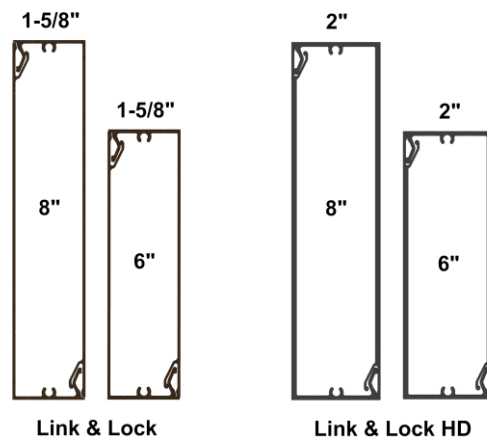

4x4 & 4x6 Link & Lock

- Available sizes: 4"x4" & 4"x6"
- Uses standard Mounting Clip and attachment methods with #12 Fasteners

Refer to System Layout and Install steps section for typical install details.

See **Appendix for allowable spans for project specific wind load.**
Allowable Span – Tables 12 & 13, Page 31

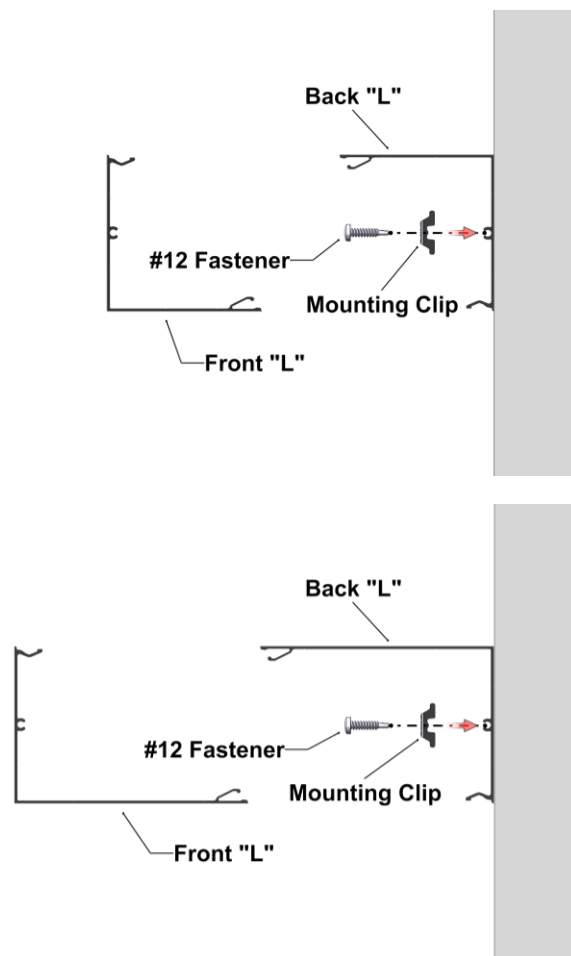

Link & Lock Brackets

- Alternate option for securing L&L cladding
- Attachment from L&L to bracket: use 1/4" Socket Head Screws, washers, locknuts & Mounting Clips included in order
- Attachment to structural element: Min #12 Fasteners (Min head diameter of 11mm) by others
- For expansion & contraction hard fasten only one fixed bracket per L&L run.
- Sliding Brackets are used for floor/slab deflection.

See Appendix for L&L Bracket Max. Spacing. Table 14, Page 32

Link & Lock Bracket Options

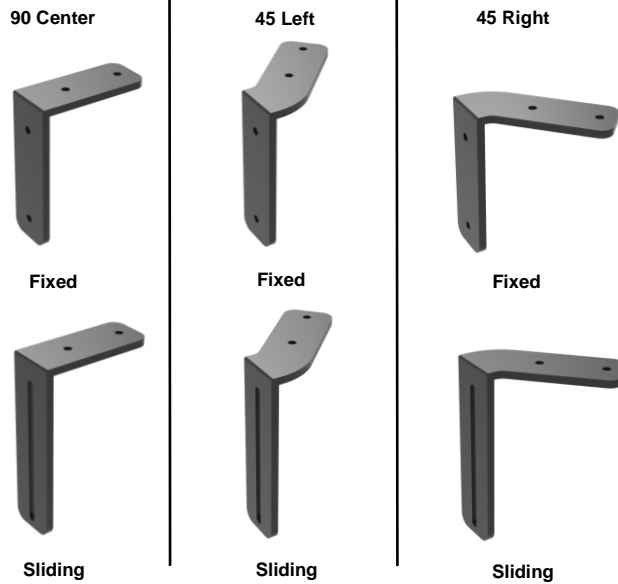

Single Bracket for horizontal substrate

Fixed Bracket (Hard fastened with 1/4" holes)

Fixed Bracket (Expansion 1/2" holes)

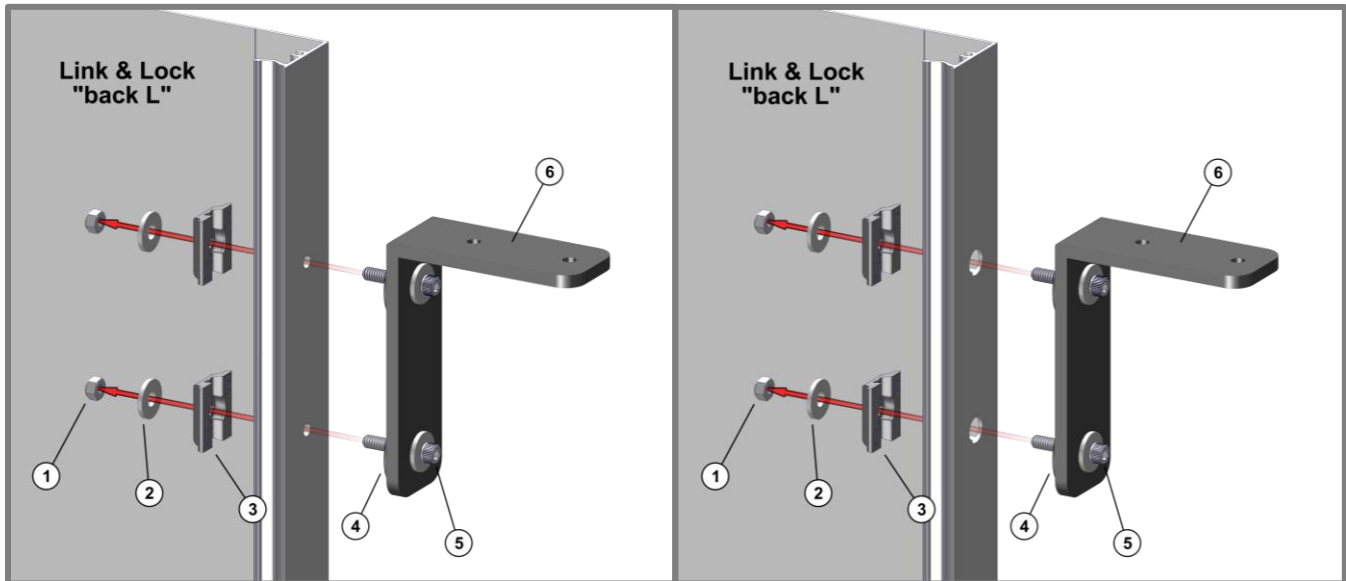

No.	Description	Material	Qty
1	1/4" -20 Locknut	Stainless Steel Nylon-Insert	2
2	Washer, 1/4" screw size, 0.75" OD	Stainless Steel	4
3	Link & Lock Mounting Clip	Nylon w. Stainless Washer	2
4	Self-Retaining Washer for 1/4" size	Nylon, Black	2
5	1/4" -20 Socket Head Screw, 1-1/4" length	Stainless Steel	2
6	Link & Lock Bracket -90 Center Fixed	6005A Aluminum	1

Sliding Bracket (Use 1/4" holes)

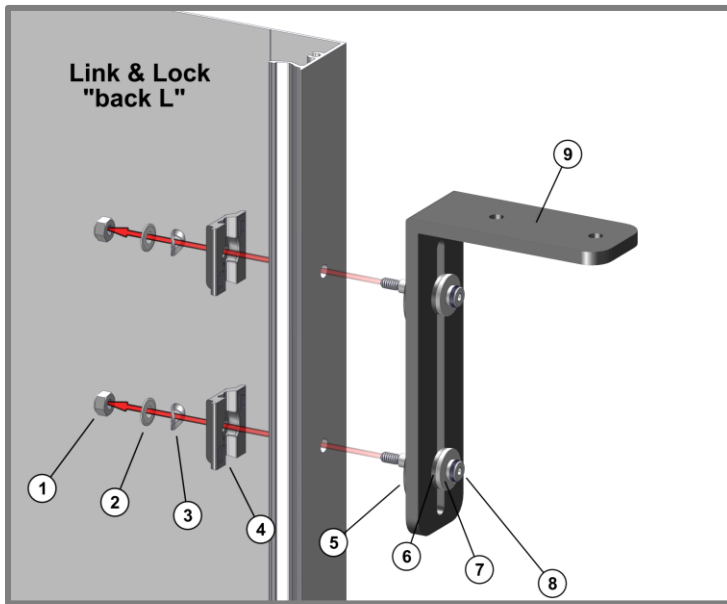

No.	Description	Material	Qty
1	10-24 Locknut	Stainless Steel Nylon-Insert	2
2	Washer, #10 screw size, 0.5" OD	Stainless Steel	2
3	Single-Wave Washer, 0.5" OD	Stainless Steel	2
4	Link & Lock Mounting Clip	Nylon w. Stainless Washer	2
5	Self-Retaining Washer for 1/4" screw size	Nylon, Black	2
6	Plastic Washer, 1/4" screw size, 0.734 OD	Nylon, Black	2
7	Washer, 1/4" screw size, 0.75" OD	Stainless Steel	2
8	1/4" Shoulder screw, 1" Shoulder length 10-24 Thread	Stainless Steel	2
9	Link & Lock Bracket -90 Center Sliding	6005A Aluminum	1

Dual Bracket for vertical substrate

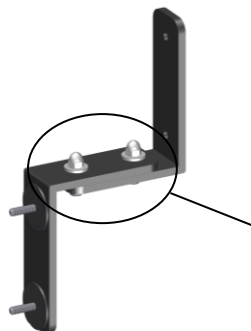
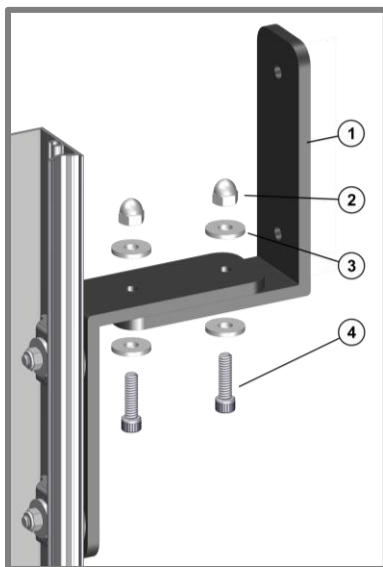

Dual Bracket components are pre-assembled by manufacturer. Do not adjust or remove unless authorized by the manufacturer.

No.	Description	Material	Qty
1	Link & Lock Dual Bracket -90 Center Fixed	6005A Aluminum	1
2	Distorted-Thread Cap Locknut	Stainless Steel	2
3	Washer, 1/4" screw size, 0.75" OD	Stainless Steel	4
4	7/8" Socket Head Screw	Stainless Steel	2

Install steps

Step 1

Layout & install Link & Lock Brackets. It is good practice to check for level/plumb and flat/straight, for best results.

⚠ TIP: Install one run of L&L Brackets with the L&L to confirm measurements.

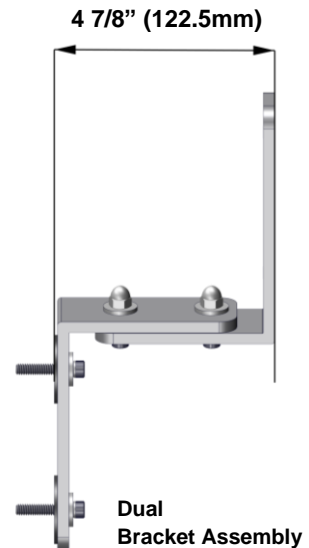
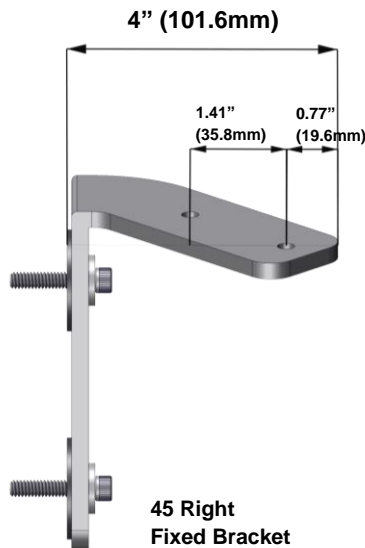
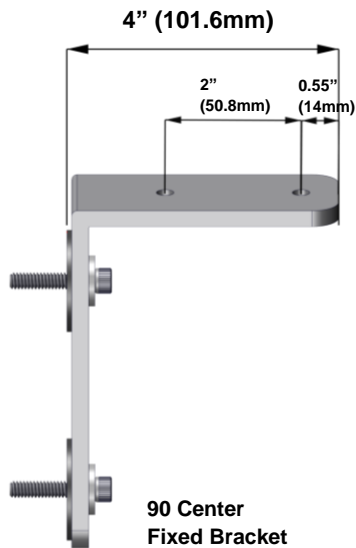
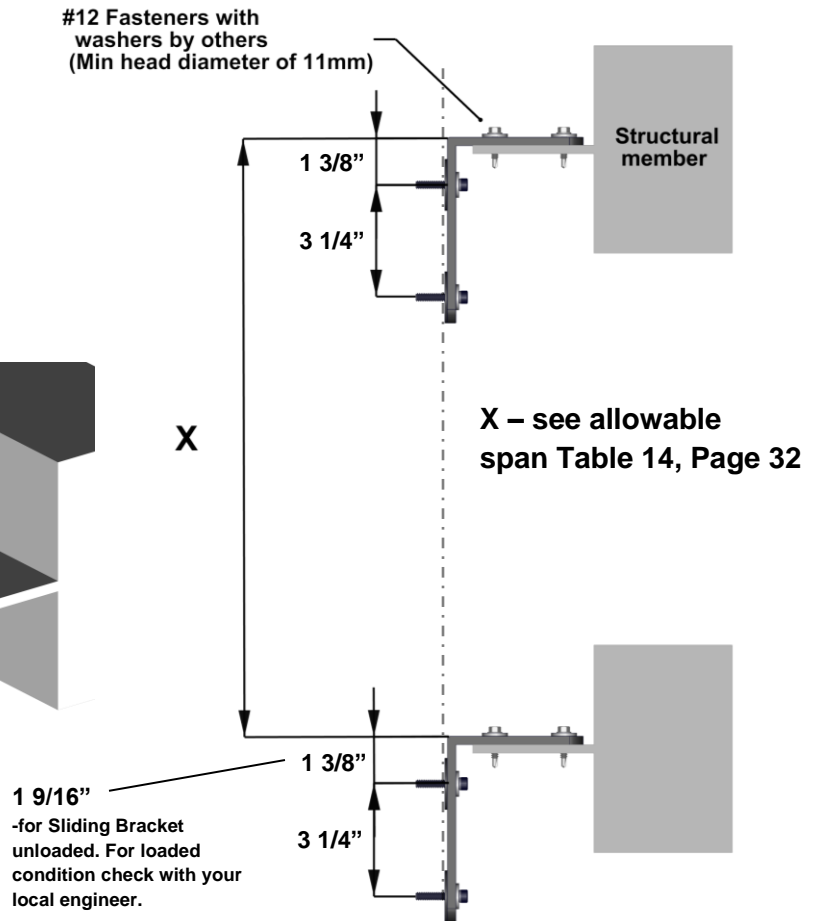
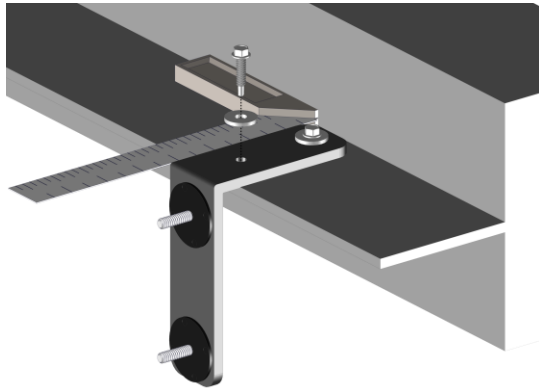

Step 2

Drill out back "L" of the Link & Lock.
For dimensions review drawing details provided by Longboard if required.

- **1/4" holes**
-for hard fastening one Bracket per run
-for Sliding Brackets if used
- **1/2" holes** for expansion & contraction on the rest of the Fixed Brackets

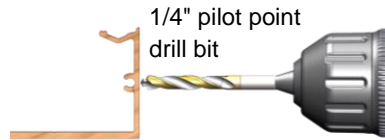

Step 3

Install back "L" onto brackets.

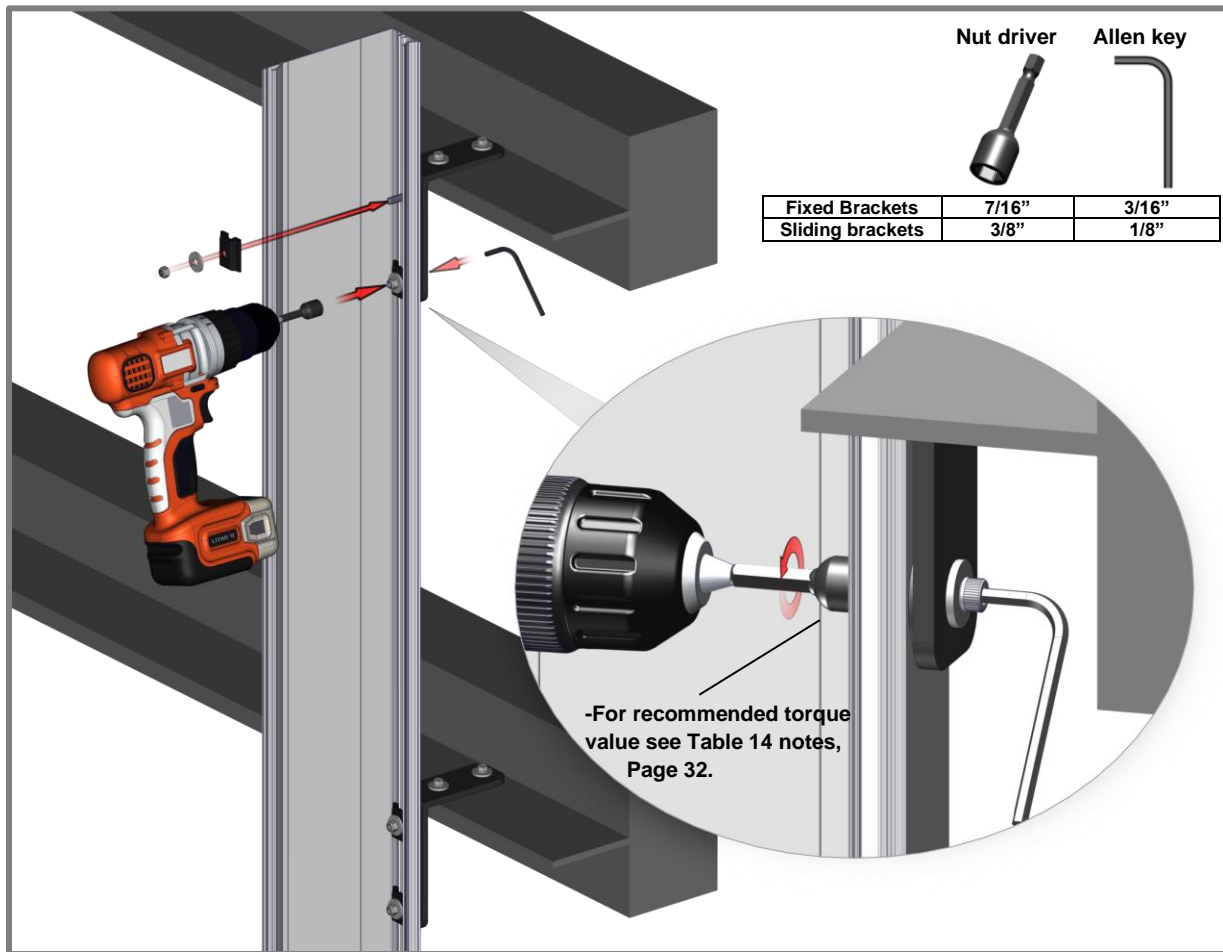

Step 3.1

Install Internal Stiffener if required. For install steps see Pages 19-20.

Step 4

Install front "L" onto back "L" and End Caps. For details See Pages 13-14, Steps 3 & 4.

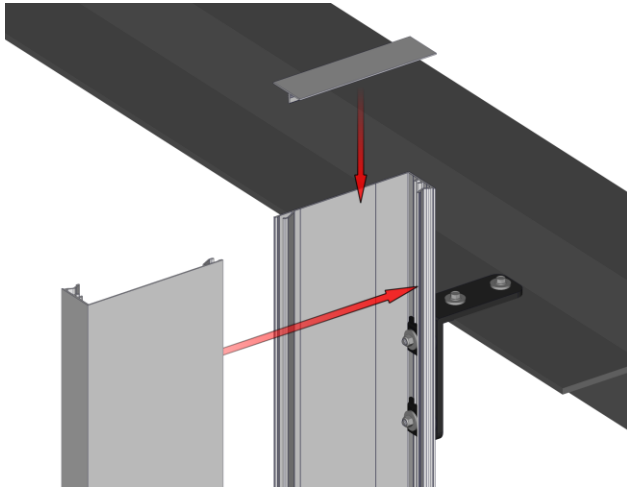

Appendix

Expansion and Contraction Tables

TABLE 1 - IMPERIAL

		AVERAGE TEMPERATURE AT TIME OF CUTTING & INSTALLATION											
°C		-50	-40	-30	-20	-10	0	10	20	30	40	50	
°F		-58	-40	-22	-4	14	32	50	68	86	104	122	
MIN/MAX POST CONSTRUCTION TEMP.	°C	°F	EXPANSION OR CONTRACTION (INCH/FOOT)										
	-50	-58	0.000	-0.003	-0.005	-0.008	-0.011	-0.014	-0.016	-0.019	-0.022	-0.024	-0.027
	-40	-40	0.003	0.000	-0.003	-0.005	-0.008	-0.011	-0.014	-0.016	-0.019	-0.022	-0.024
	-30	-22	0.005	0.003	0.000	-0.003	-0.005	-0.008	-0.011	-0.014	-0.016	-0.019	-0.022
	-20	-4	0.008	0.005	0.003	0.000	-0.003	-0.005	-0.008	-0.011	-0.014	-0.016	-0.019
	-10	14	0.011	0.008	0.005	0.003	0.000	-0.003	-0.005	-0.008	-0.011	-0.014	-0.016
	0	32	0.014	0.011	0.008	0.005	0.003	0.000	-0.003	-0.005	-0.008	-0.011	-0.014
	10	50	0.016	0.014	0.011	0.008	0.005	0.003	0.000	-0.003	-0.005	-0.008	-0.011
	20	68	0.019	0.016	0.014	0.011	0.008	0.005	0.003	0.000	-0.003	-0.005	-0.008
	30	86	0.022	0.019	0.016	0.014	0.011	0.008	0.005	0.003	0.000	-0.003	-0.005
	40	104	0.024	0.022	0.019	0.016	0.014	0.011	0.008	0.005	0.003	0.000	-0.003
	50	122	0.027	0.024	0.022	0.019	0.016	0.014	0.011	0.008	0.005	0.003	0.000

TABLE 2 - METRIC

		AVERAGE TEMPERATURE AT TIME OF CUTTING & INSTALLATION											
°C		-50	-40	-30	-20	-10	0	10	20	30	40	50	
°F		-58	-40	-22	-4	14	32	50	68	86	104	122	
MIN/MAX POST CONSTRUCTION TEMP.	°C	°F	EXPANSION OR CONTRACTION (MM/METER)										
	-50	-58	0.000	-0.230	-0.460	-0.690	-0.920	-1.150	-1.380	-1.610	-1.840	-2.070	-2.300
	-40	-40	0.230	0.000	-0.230	-0.460	-0.690	-0.920	-1.150	-1.380	-1.610	-1.840	-2.070
	-30	-22	0.460	0.230	0.000	-0.230	-0.460	-0.690	-0.920	-1.150	-1.380	-1.610	-1.840
	-20	-4	0.690	0.460	0.230	0.000	-0.230	-0.460	-0.690	-0.920	-1.150	-1.380	-1.610
	-10	14	0.920	0.690	0.460	0.230	0.000	-0.230	-0.460	-0.690	-0.920	-1.150	-1.380
	0	32	1.150	0.920	0.690	0.460	0.230	0.000	-0.230	-0.460	-0.690	-0.920	-1.150
	10	50	1.380	1.150	0.920	0.690	0.460	0.230	0.000	-0.230	-0.460	-0.690	-0.920
	20	68	1.610	1.380	1.150	0.920	0.690	0.460	0.230	0.000	-0.230	-0.460	-0.690
	30	86	1.840	1.610	1.380	1.150	0.920	0.690	0.460	0.230	0.000	-0.230	-0.460
	40	104	2.070	1.840	1.610	1.380	1.150	0.920	0.690	0.460	0.230	0.000	-0.230
	50	122	2.300	2.070	1.840	1.610	1.380	1.150	0.920	0.690	0.460	0.230	0.000

TABLE 3

2" LINK & LOCK		PSF (FACTORED/ULTIMATE)										
		30	40	50	60	70	80	90	100	110	120	
ALLOWABLE SPAN (ft)	4'	✓	✓	✓	✓	✓	✓	✓	✓	✓	✓	✓
	6'	✓	✓	✓	✓	✓	✓	✓	✓	✓	✓	✓
	8'	✓	✓	✓	✓	✓	✓	✓	✓	✓	✓	✓
	10'	✓	✓	✓	✓	✓	✓	✓	✓	✓	✓	✓

All testing has been performed using L/180 deflection limits

TABLE 4

4" LINK & LOCK		PSF (FACTORED/ULTIMATE)										
		30	40	50	60	70	80	90	100	110	120	
ALLOWABLE SPAN (ft)	2'	✓	✓	✓	✓	✓	✓	✓	✓	✓	✓	✓
	4'	✓	✓	✓	✓	✓	✓	✓	✓	✓	✓	✓
	6'	✓	✓	✓	✓	✓	✓	✓	✓	✓	✓	✓
	8'	✓	✓	✓	✓	✓	✓	✓	✓	✓	✓	✓

All testing has been performed using L/180 deflection limits

TABLE 5

6" LINK & LOCK		PSF (FACTORED/ULTIMATE)										
		30	40	50	60	70	80	90	100	110	120	
ALLOWABLE SPAN (ft)	2'	✓	✓	✓	✓	✓	✓	✓	✓	✓	✓	✓
	4'	✓	✓	✓	✓	✓	✓	✓	✓	✓	✓	✓
	6'	✓	✓	✓	✓	✓	✓	✓	✓	✓	✓	✓

All testing has been performed using L/180 deflection limits

TABLE 6

8" LINK & LOCK		PSF (FACTORED/ULTIMATE)										
		30	40	50	60	70	80	90	100	110	120	
ALLOWABLE SPAN (ft)	2'	✓	✓	✓	✓	✓	✓	✓	✓	✓	✓	✓
	4'	✓	✓	✓	✓	✓	✓	✓	✓	✓	✓	✓
	6'	✓	✓	✓	✓	✓	✓	✓	✓	✓	✓	✓

All testing has been performed using L/180 deflection limits

TABLE 7

		PSF (FACTORED/ULTIMATE)													
		30	40	50	60	70	80	90	100	110	120				
ALLOWABLE SPAN (ft)	4" LINK & LOCK W. STIFFENER	**4'													
	**6'														
	**8'														
	**10'														
	**12'														

All testing has been performed using L/180 deflection limits
 **Using Longboard Link & Lock Internal Stiffener

TABLE 8

		PSF (FACTORED/ULTIMATE)													
		30	40	50	60	70	80	90	100	110	120				
ALLOWABLE SPAN (ft)	6" LINK & LOCK W. STIFFENER	**4'													
	**6'														
	**8'														
	**10'														

All testing has been performed using L/180 deflection limits
 **Using Longboard Link & Lock Internal Stiffener

TABLE 9

		PSF (FACTORED/ULTIMATE)													
		30	40	50	60	70	80	90	100	110	120				
ALLOWABLE SPAN (ft)	8" LINK & LOCK W. STIFFENER	**2'													
	**4'														
	**6'														
	**8'														

All testing has been performed using L/180 deflection limits
 **Using Longboard Link & Lock Internal Stiffener

TABLE 10

6" LINK & LOCK HD		PSF (FACTORED/ULTIMATE)									
		30	40	50	60	70	80	90	100	110	120
ALLOWABLE SPAN (ft)	8'	✓	✓	✓	✓	✓					
	10'	✓	✓	✓							
	12'	✓									

All testing has been performed using L/180 deflection limits

TABLE 11

8" LINK & LOCK HD		PSF (FACTORED/ULTIMATE)									
		30	40	50	60	70	80	90	100	110	120
ALLOWABLE SPAN (ft)	4'	✓	✓	✓	✓	✓	✓	✓	✓	✓	✓
	6'	✓	✓	✓	✓	✓					
	8'	✓	✓	✓							
	10'	✓									

All testing has been performed using L/180 deflection limits

TABLE 12

4X4 LINK & LOCK		PSF (FACTORED/ULTIMATE)									
		30	40	50	60	70	80	90	100	110	120
ALLOWABLE SPAN (ft)	8'	✓	✓	✓	✓	✓	✓	✓	✓	✓	✓
	10'	✓	✓	✓	✓	✓	✓				
	12'	✓	✓	✓							

All testing has been performed using L/180 deflection limits

TABLE 13

4X6 LINK & LOCK		PSF (FACTORED/ULTIMATE)									
		30	40	50	60	70	80	90	100	110	120
ALLOWABLE SPAN (ft)	8'	✓	✓	✓	✓	✓	✓	✓			
	10'	✓	✓	✓	✓						
	12'	✓	✓								

All testing has been performed using L/180 deflection limits

TABLE 14

LONGBOARD® INSPIRING ARCHITECTURE	LINK & LOCK™ BRACKET MAX. SPACING (FT)									
	WIND LOAD PSF (FACTORED/ULTIMATE)									
LINK & LOCK™ BATTEN	30	40	50	60	70	80	90	100	110	120
1-5/8" x 2"	10'	8'				6'				4'
1-5/8" x 4"	8'	6'		4'				2'		
1-5/8" x 4" w. Internal Stiffener	12'	10'	8'		6'			4'		
1-5/8" x 6"		6'			4'				3'	2'
1-5/8" x 6" w. Internal Stiffener	10'	8'	6'		4'				3'	
1-5/8" x 8"	6'	4'					2'			
1-5/8" x 8" w. Internal Stiffener	8'	6'		4'			3'			2'
2" x 6" HD	10	8'	6'		4'				3'	
2" x 8" HD	8'	6'		4'			3'			2'

Recommended torque value for Link & Lock™ to Bracket attachment:

note 1 Factored Wind Load: max. 168 LBS/EA Bracket
 note 2 Factored Dead Load: max. 29 LBS/EA Fixed Bracket
 note 3 Fixed Bracket 1/4" -20 Socket Head Screw, 60 in/lbs + prevailing torque of self-locking nut
 note 4 Sliding Bracket 1/4" Shoulder Socket Head Screw (#10-24 thread), 20 in/lbs + prevailing torque of self-locking nut

Proper Handling of Longboard Products



To help avoid injury and product damage, Longboard products require proper handling to and from storage areas during installation. When carrying or installing any products it is recommended that they be moved or carried by at least two people with each support point approximately 4ft from the ends. **Carrying products without proper support can cause excessive bending which may damage the appearance or finish of the product.** Any short cut lengths should also be carried on edge while supporting the material. See below for details.

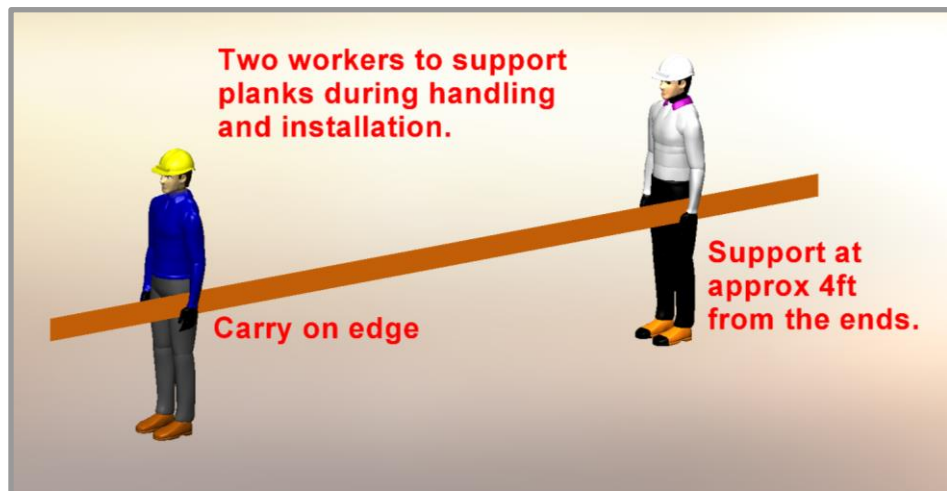
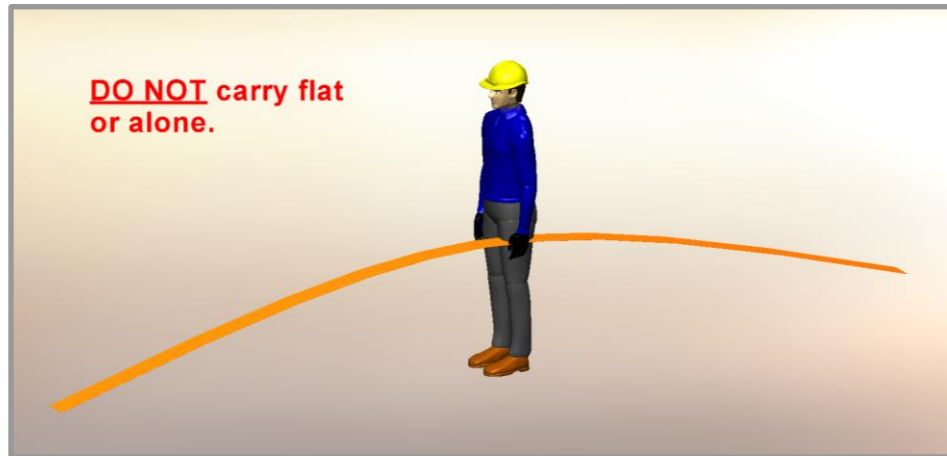

⚠️ Delivery, Storage & Handling ⚠️

- Always inspect the delivery for damage and contact LB ASAP if there are any issues: info@longboardproducts.com or 1-800-604-0343 and include your PO# and any pictures if possible. Longboard is not responsible for the installation of blemished or damaged material.
- Be sure to store the material flat, keep it dry, safe & secure and remain in unopened cartons until ready to be installed.
- Always wear appropriate PPE when handling products.



Longboard Architectural Products Inc.
© Longboard Architectural Products Inc. All rights reserved.

Longboard® is a registered trademark of Longboard Architectural Products Inc.

Longboard
1777 Clearbrook Road
Abbotsford, BC V2T 8X8
Canada
longboardproducts.com

Every effort has been made to ensure that the information in these installation guidelines is accurate. Longboard is not responsible for printing or clerical errors.

For more information, contact client care at info@longboardproducts.com or call toll free 1-800-604-0343.